

Specs: F-15 Park Jet

3D FOAMY

Copyright © 2004 3DFoamy.com.
 All rights reserved.
 Designed and Drawn by:
 Steve Shumate & Levi Jordan
 Updated: 0/19/2004

Weight	14-18 oz.
Thrust	14-24 oz.
Radio	4-5 Chanel
Area	289.7 in2
Loading	6.5-8.6 oz/ft2
WWW.3DFOAMY.COM	

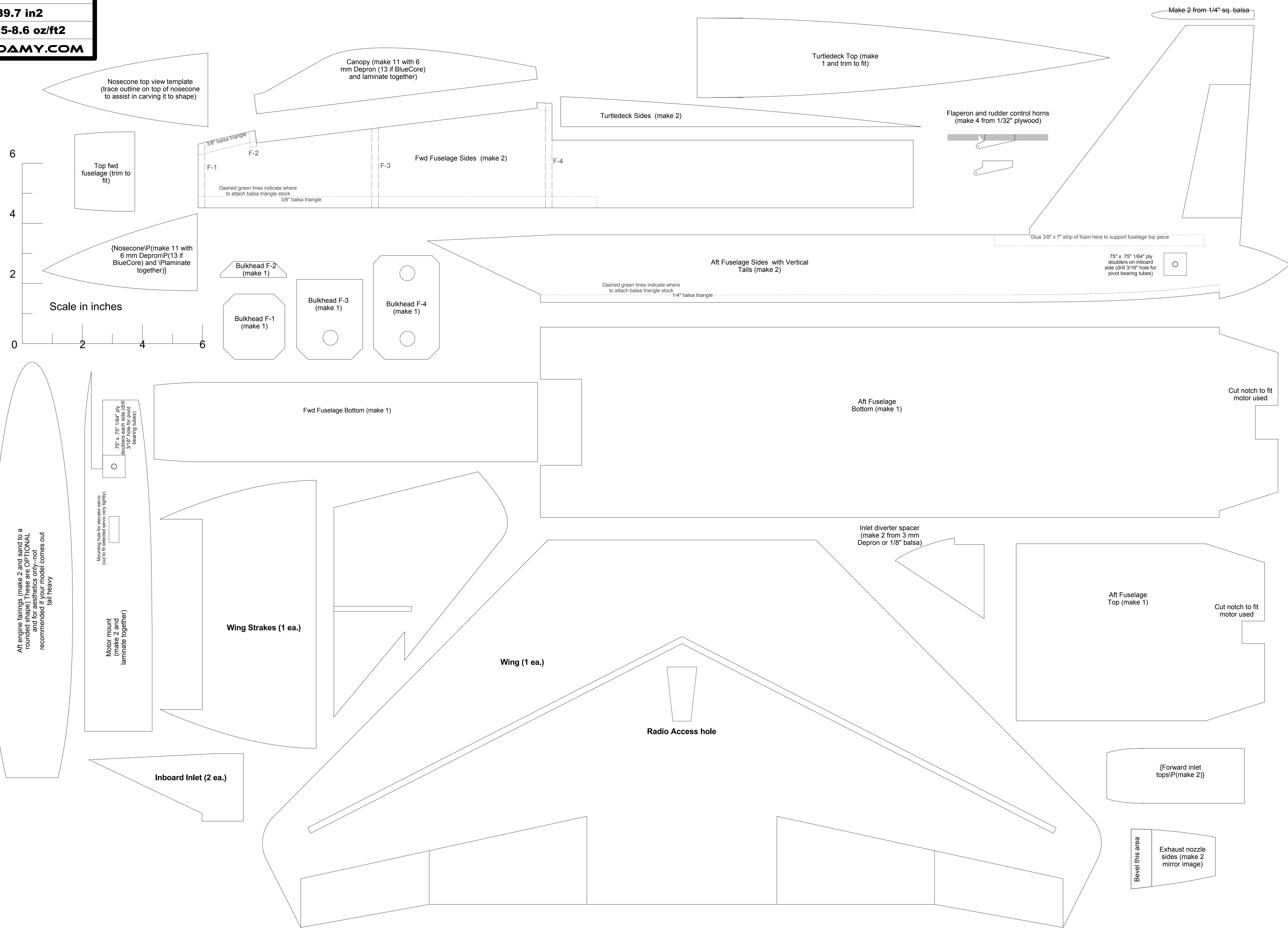

Nosecone top view template
 (trace outline on top of nosecone
 to assist in carving it to shape)

Canopy (make 11 with 6
 mm Depron (13 if BlueCore)
 and laminate together)

Turtledeck Top (make
 1 and trim to fit)

Turtledeck Sides (make 2)

Flaperon and rudder control horns
 (make 4 from 1/32" plywood)

Top fwd
 fuselage (trim to
 fit)

Fwd Fuselage Sides (make 2)

Aft Fuselage Sides with Vertical
 Tails (make 2)

Scale in inches

(Nosecone)P(make 11 with
 6 mm Depron(13 if
 BlueCore) and laminate
 together)

Bulkhead F-2
 (make 1)

Bulkhead F-1
 (make 1)

Bulkhead F-3
 (make 1)

Bulkhead F-4
 (make 1)

.75" x .75" 1/64" ply
 doublers on inboard
 side (drill 3/16" hole for
 pivot bearing tubes)

Make 2 from 1/4" sq. balsa

Dashed green lines indicate where
 to attach balsa triangle stock
 1/4" balsa triangle

Glue 3/8" x 7" strip of foam here to support fuselage top piece

Cut notch to fit
 motor used

Aft Fuselage
 Bottom (make 1)

Fwd Fuselage Bottom (make 1)

Aft engine fairings (make 2 and sand to a
 rounded shape. OPTIONAL
 for aesthetics only - not
 recommended if your model comes out
 tail heavy)

Mounting hole for elevator servo
 (cut to fit selected servo very tightly)

Motor mount
 (make 2 from
 1/8" ply and
 laminate together)

3/8" x 3/8" x 1/8" ply
 doublers each side (drill
 3/16" hole for pivot
 bearing tubes)

Wing Strakes (1 ea.)

Wing (1 ea.)

Radio Access hole

Inlet diverter spacer
 (make 2 from 3 mm
 Depron or 1/8" balsa)

Aft Fuselage
 Top (make 1)

Cut notch to fit
 motor used

Inboard Inlet (2 ea.)

(Forward inlet
 tops)P(make 2))

Bevel this area

Exhaust nozzle
 sides (make 2
 mirror image)

Specs:

F-15 Park

3D FOAMY

Copyright © 2008
All rights reserved
Designed and Drawn by
Steve Shumate
Updated: 0/19/2008

Weight	14-18 oz.
Thrust	14-24 oz.
Radio	4-5 Chanel
Area	289.7 in2
Loading	6.5-8.6 oz/ft2

WWW.3DFOAMY.COM

Jet

© 2004 3DFoamy.com.
All rights reserved.
Designed and drawn by:
Levi Jordan
2004

Canopy (make 11 with 6

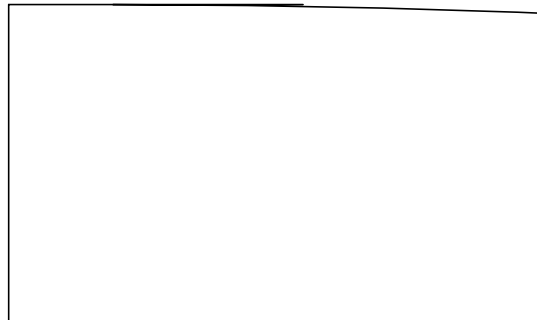

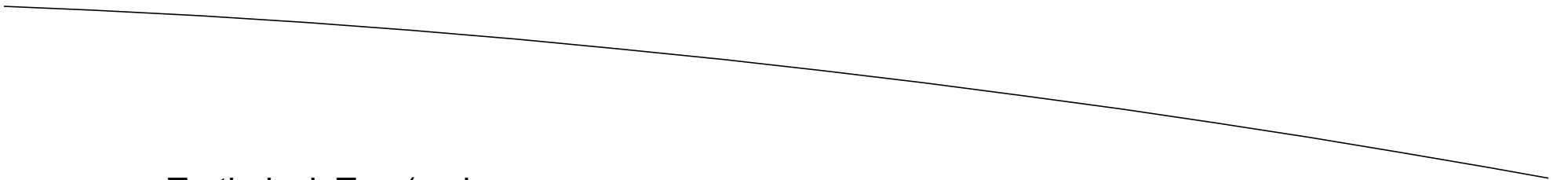

Turtledeck Top (make
1 and trim to fit)



Make 2 from 1/4" sq. balsa

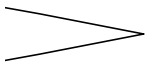
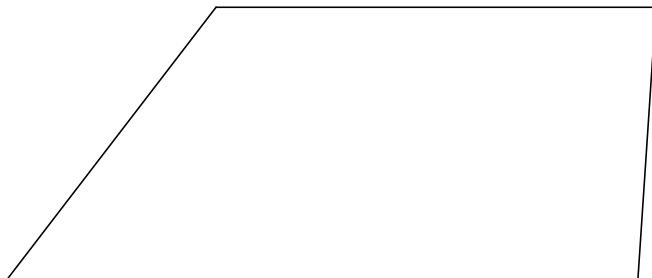
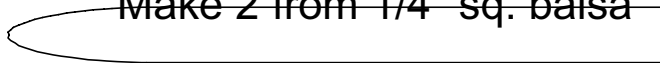

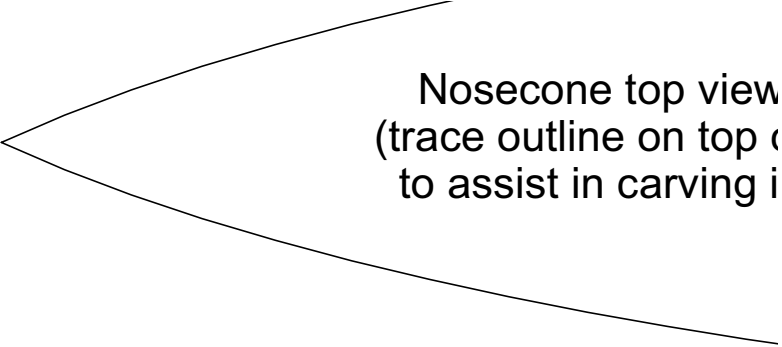

Nosecone top view
(trace outline on top of
to assist in carving i

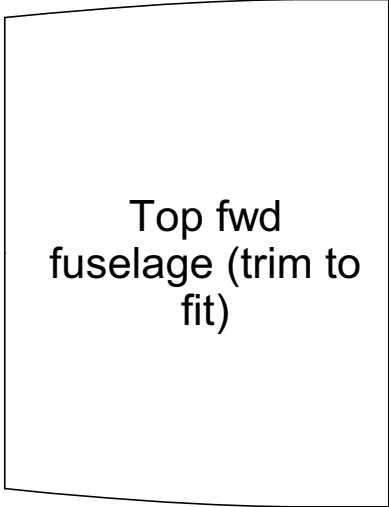

Top fwd
fuselage (trim to
fit)

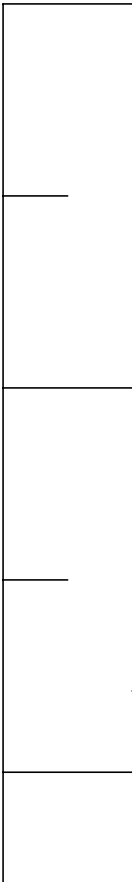

6

4

2

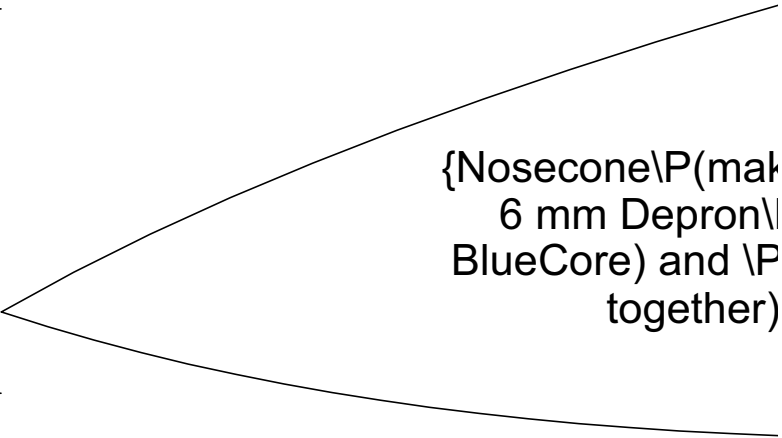

{Nosecone\P(mak
6 mm Depron\
BlueCore) and \P
together)

(template
of nosecone
to shape)

mm Depron (13 if BlueCore)
and laminate together)

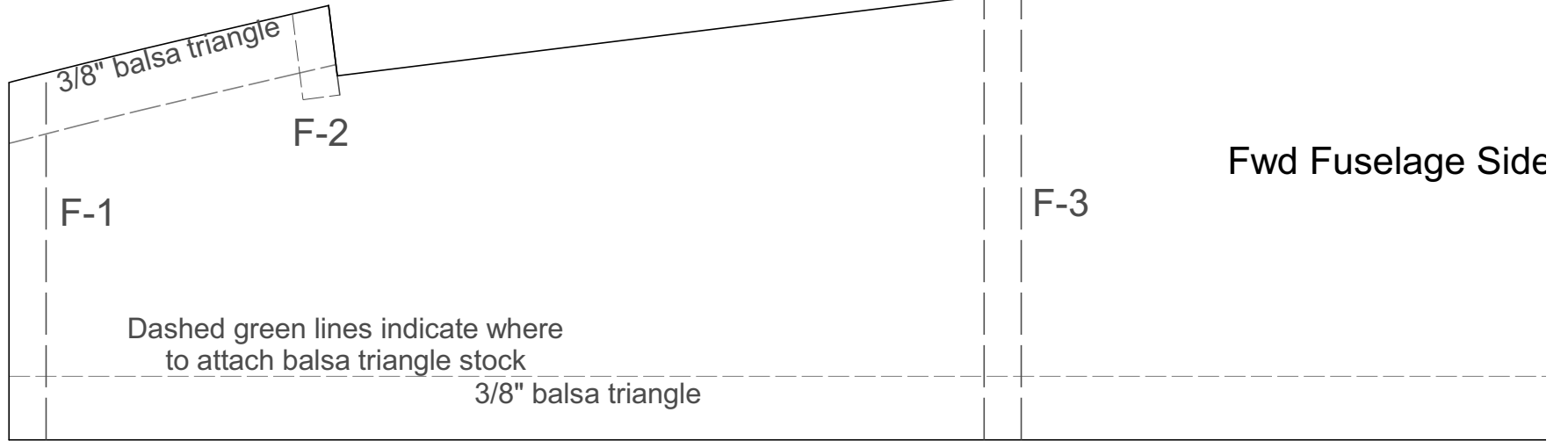

ce 11 with
P(13 if
'laminate
)

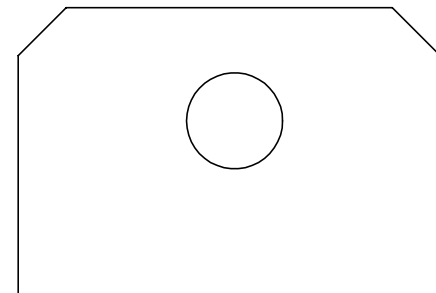
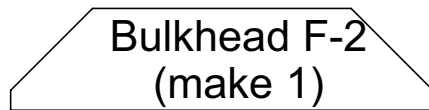

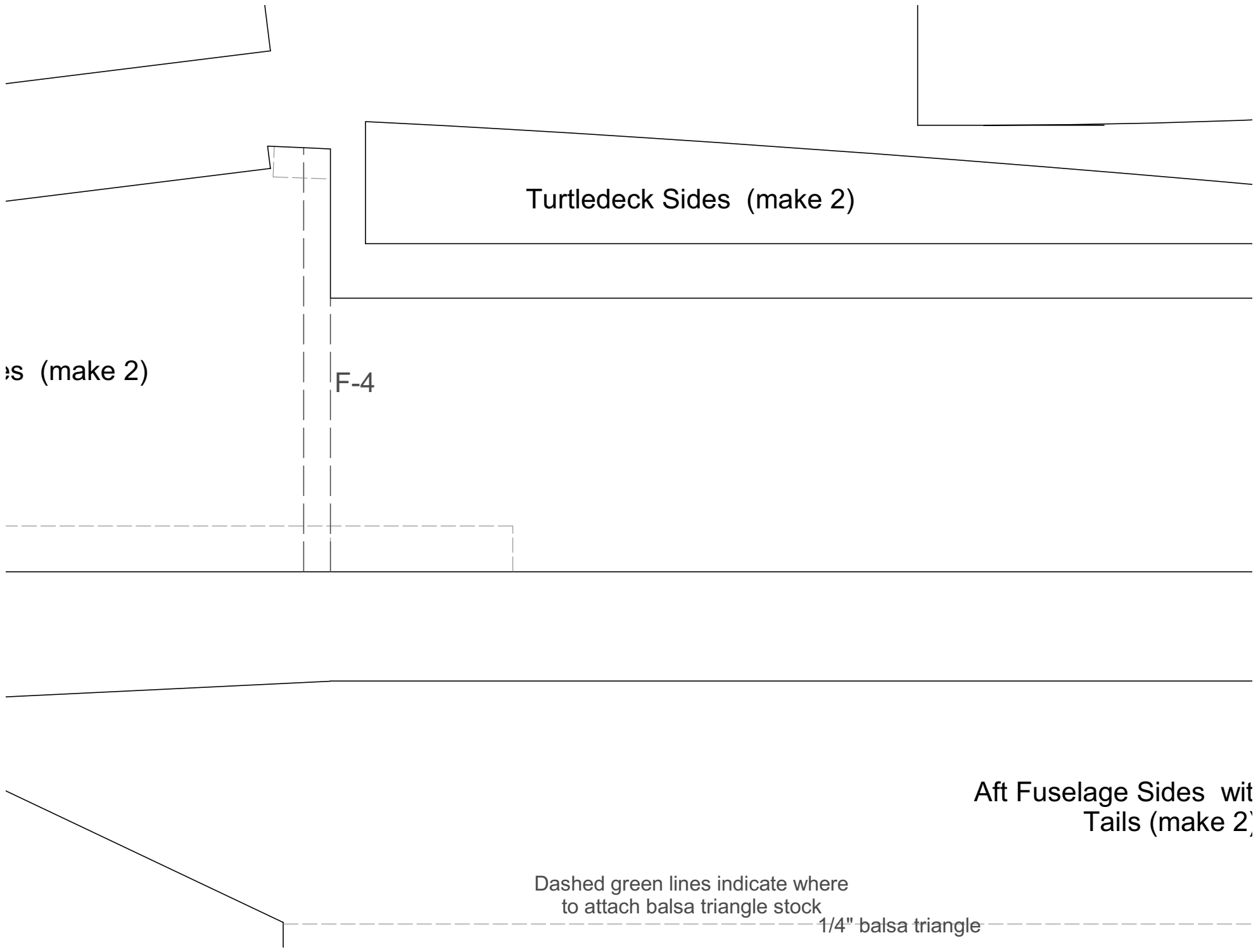

Turtledeck Sides (make 2)

s (make 2)

F-4

Aft Fuselage Sides with
Tails (make 2)

Dashed green lines indicate where
to attach balsa triangle stock

1/4" balsa triangle

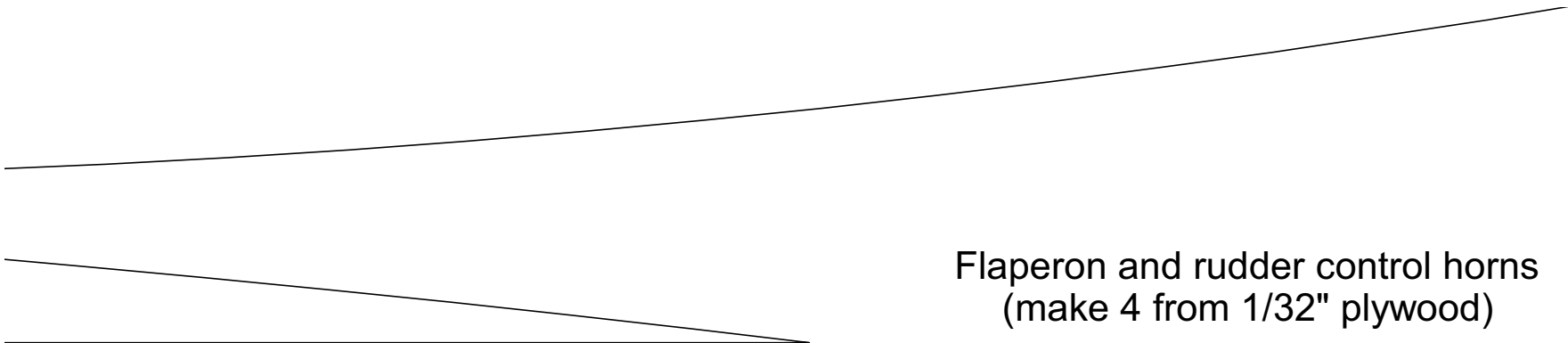

Flaperon and rudder control horns
(make 4 from 1/32" plywood)

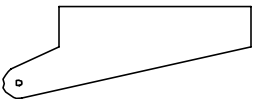

Glue 3/8" x 7" strip of foam

h Vertical
)

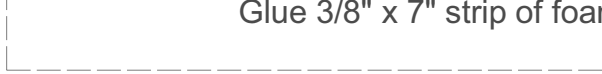

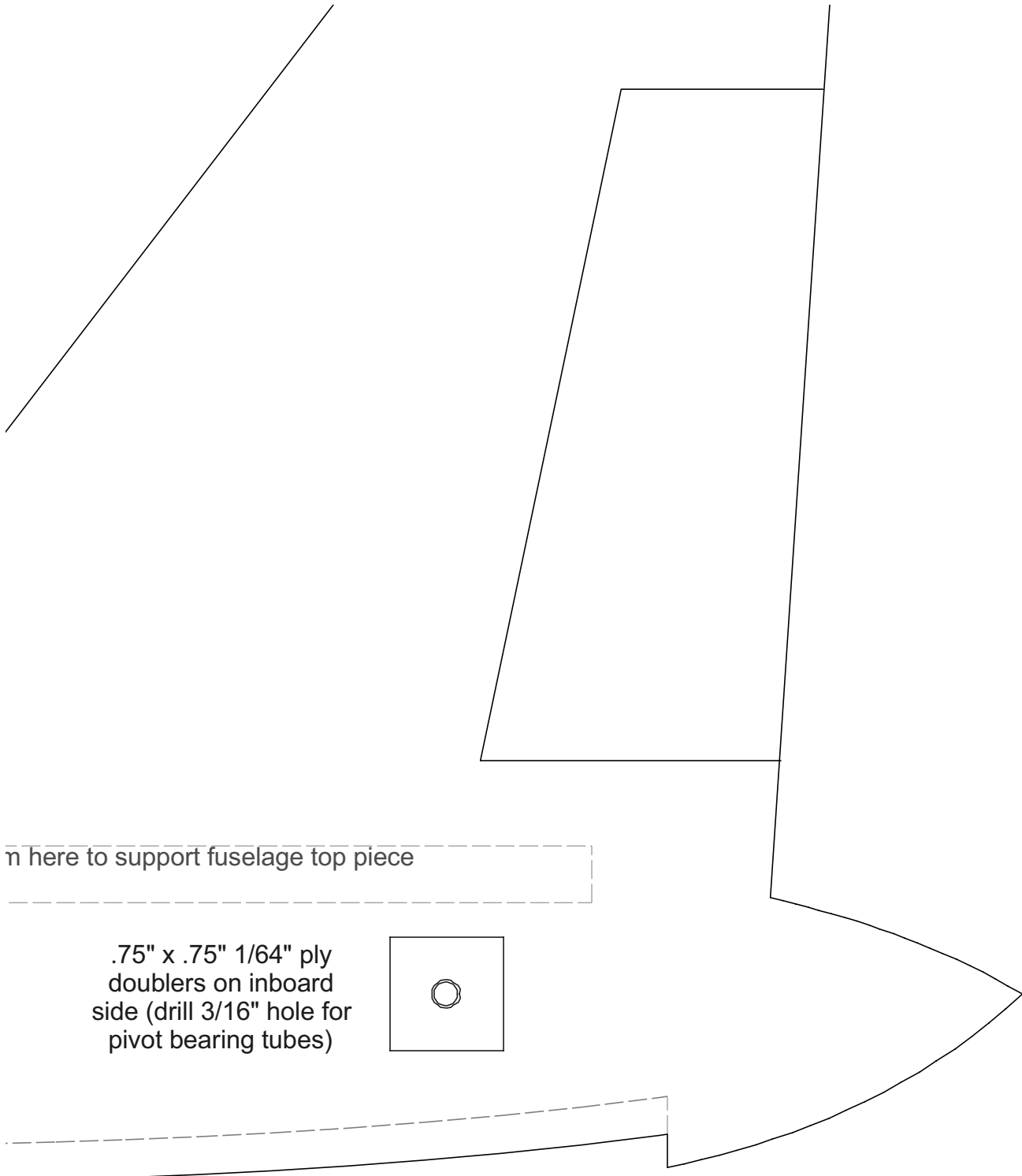

n here to support fuselage top piece

.75" x .75" 1/64" ply
doubblers on inboard
side (drill 3/16" hole for
pivot bearing tubes)

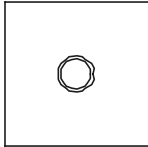

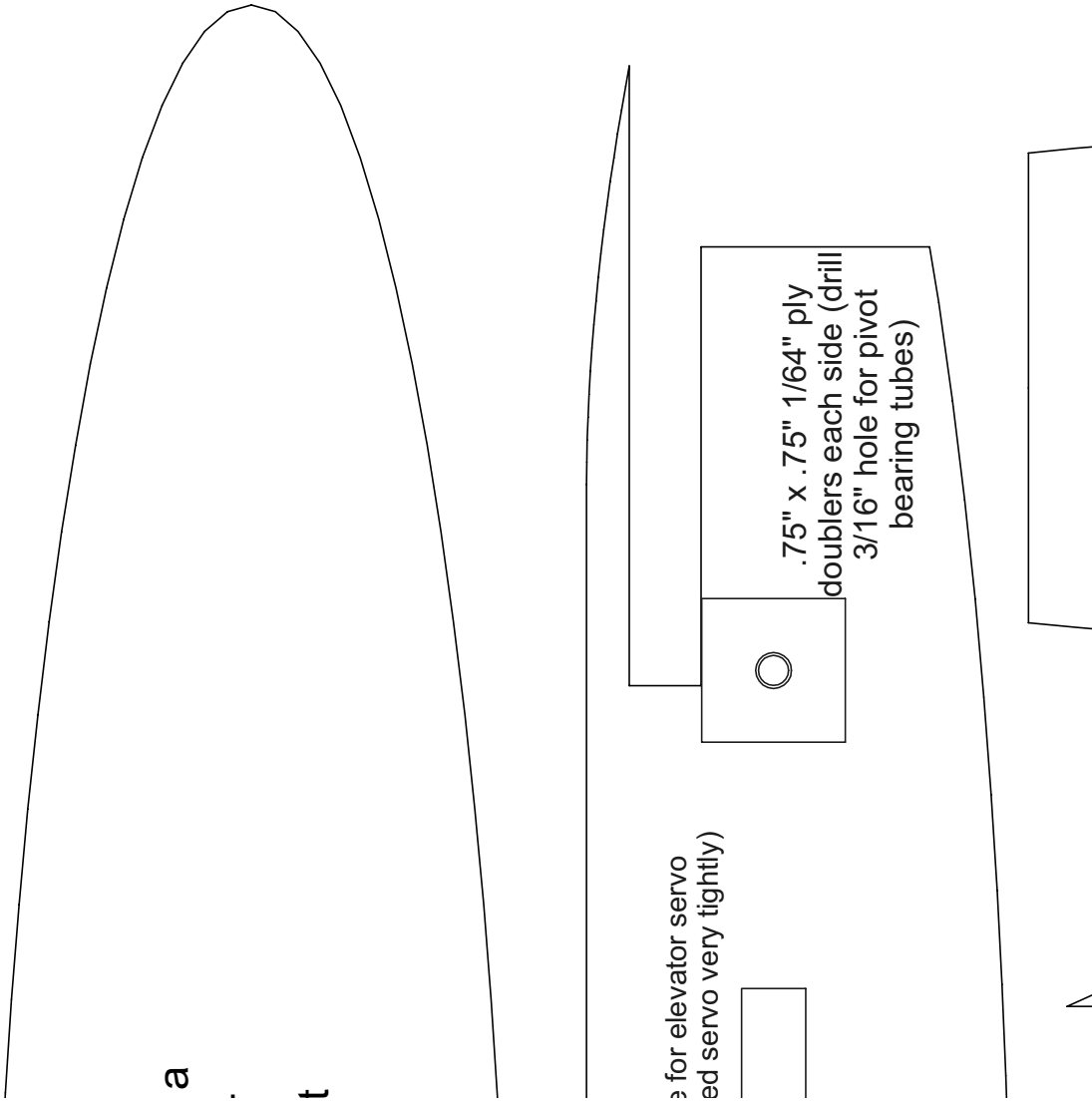

6

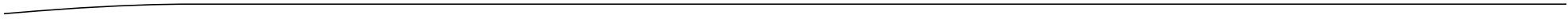
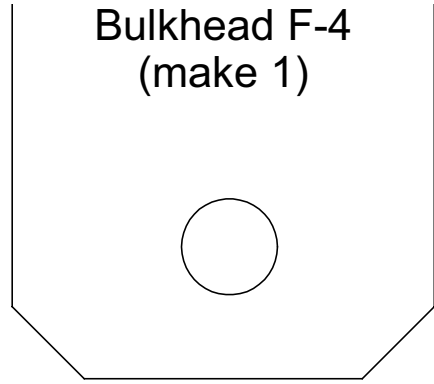
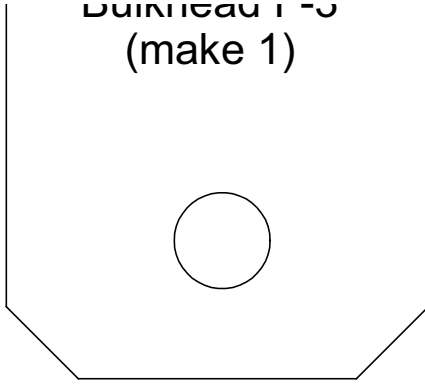
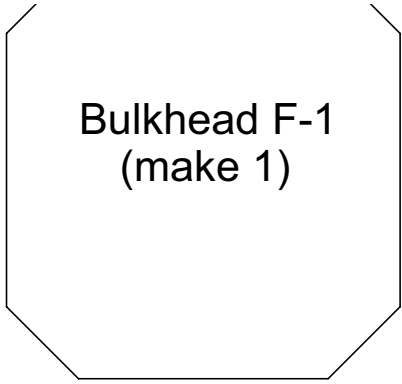

Fwd Fuselage Bottom (make 1)

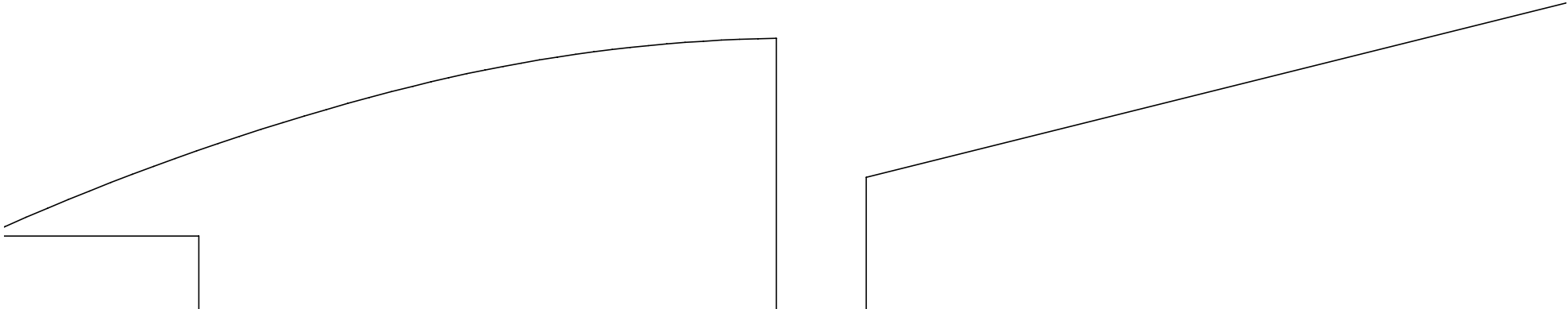

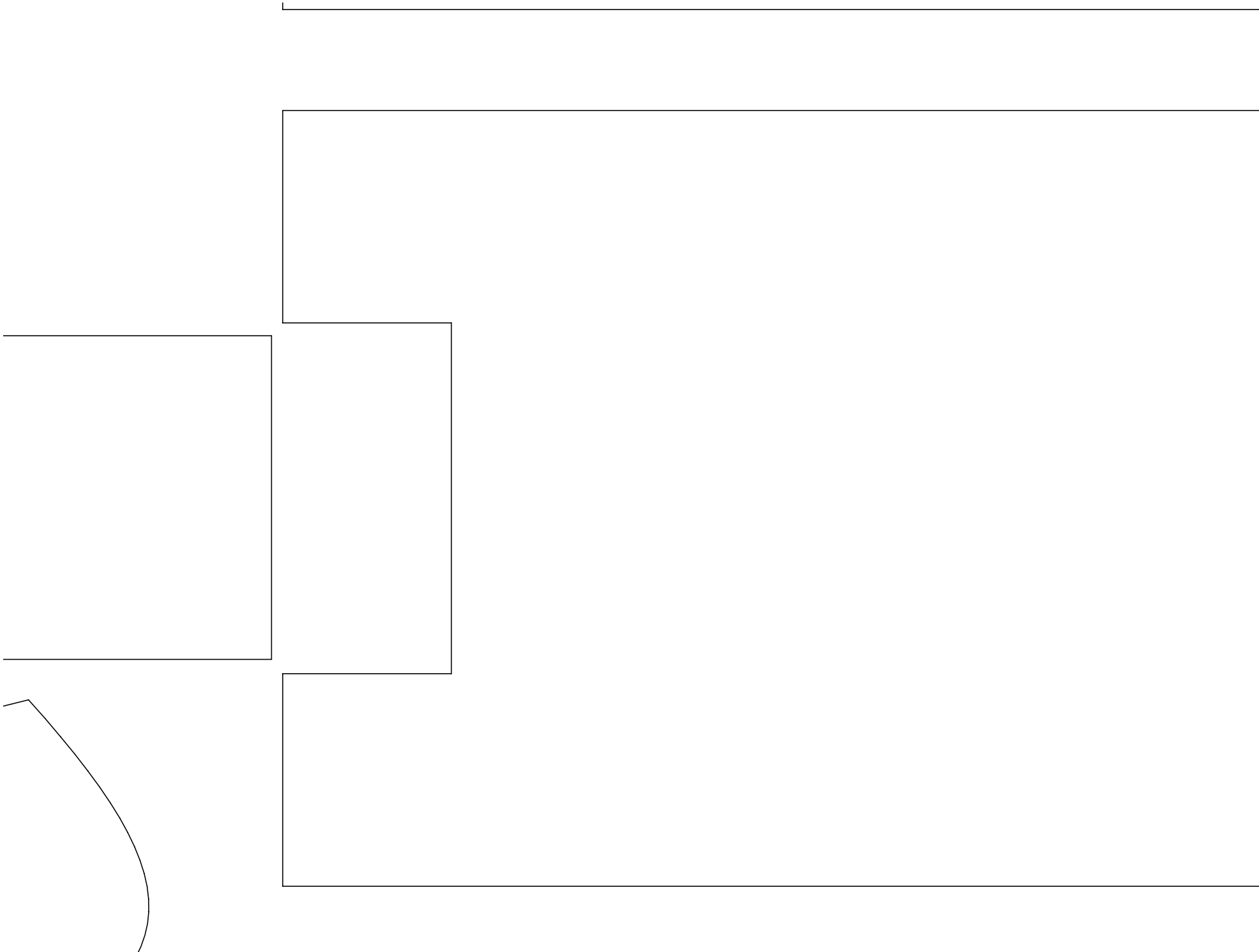

Aft Fuselage
Bottom (make 1)

Inlet diverter spacer

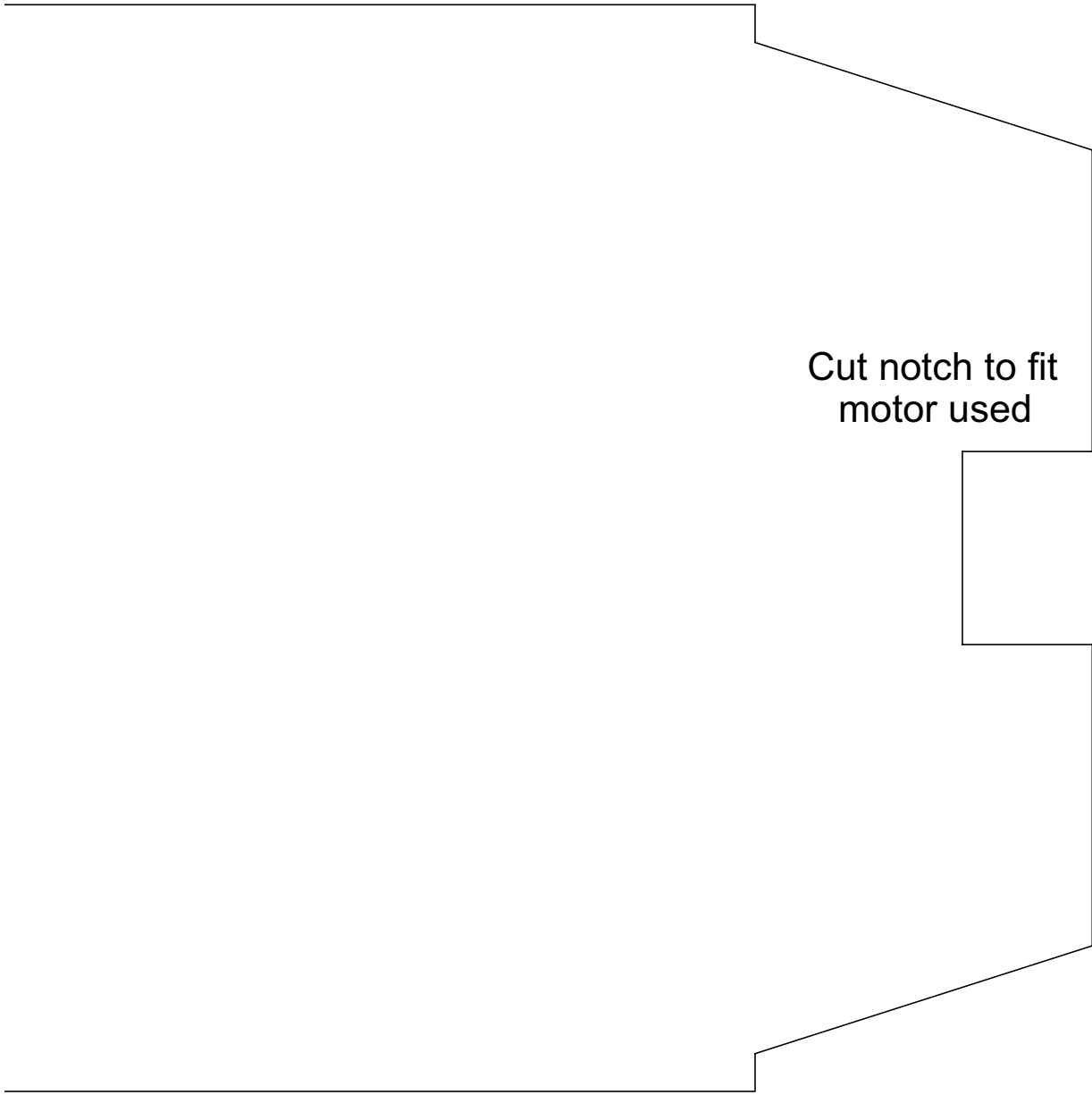

Cut notch to fit
motor used



Aft engine fairings (make 2 and sand to rounded shape) These are **OPTIONAL** and for aesthetics only--not recommended if your model comes out tail heavy

Motor mount
(make 2 and laminate together)

Mounting hole
(cut to fit select



Wing Strakes (1 ea.)

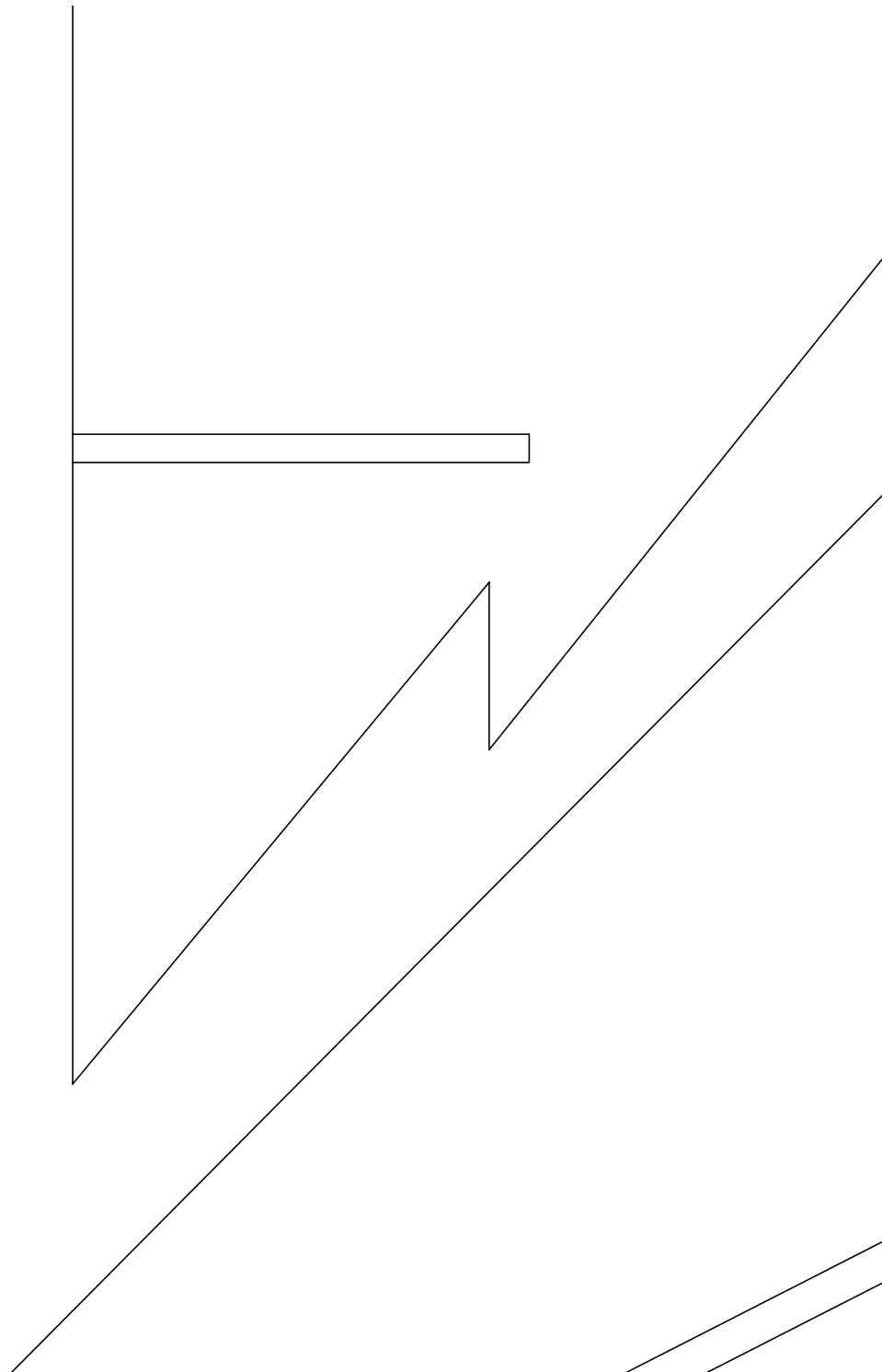
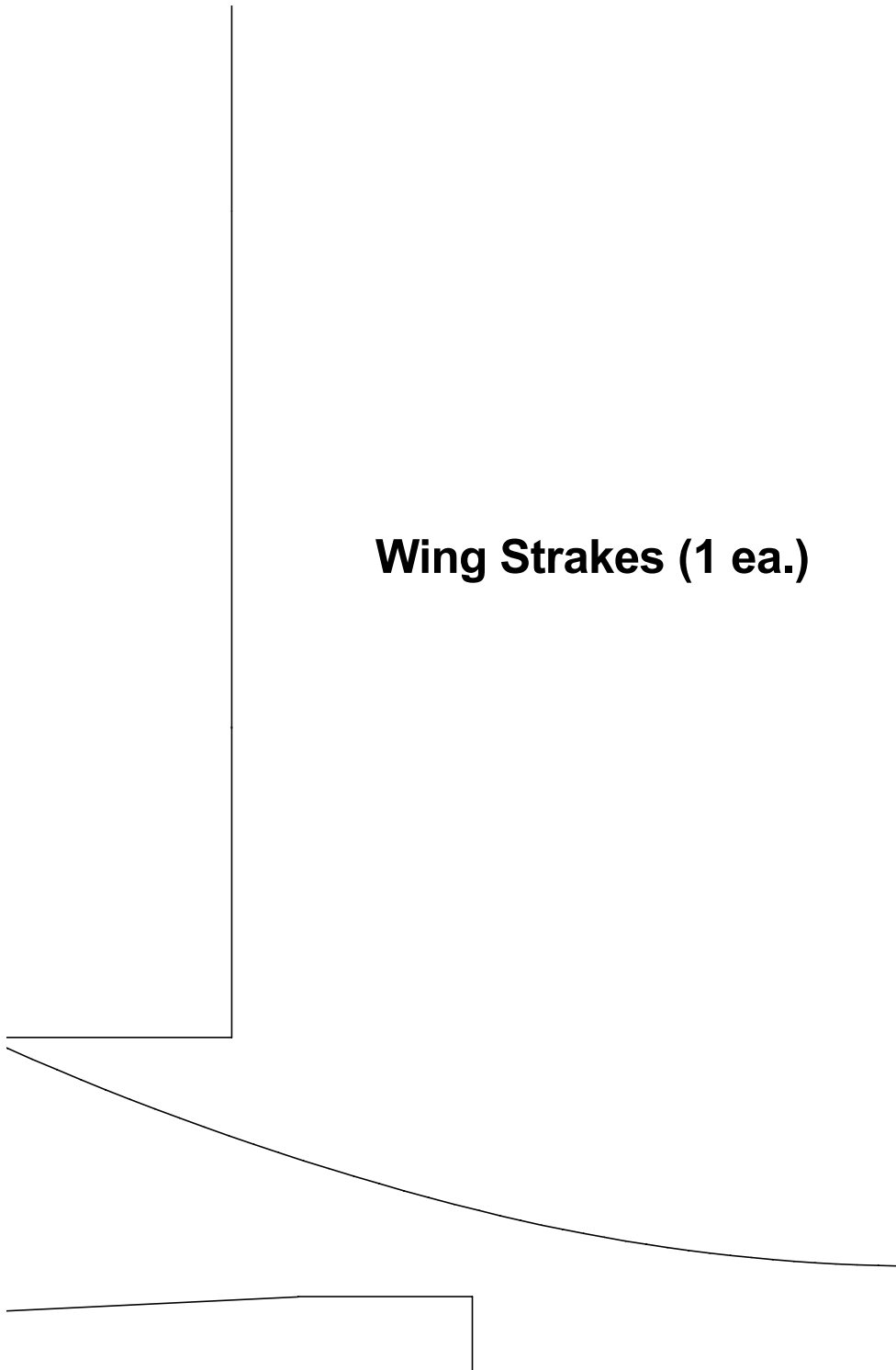

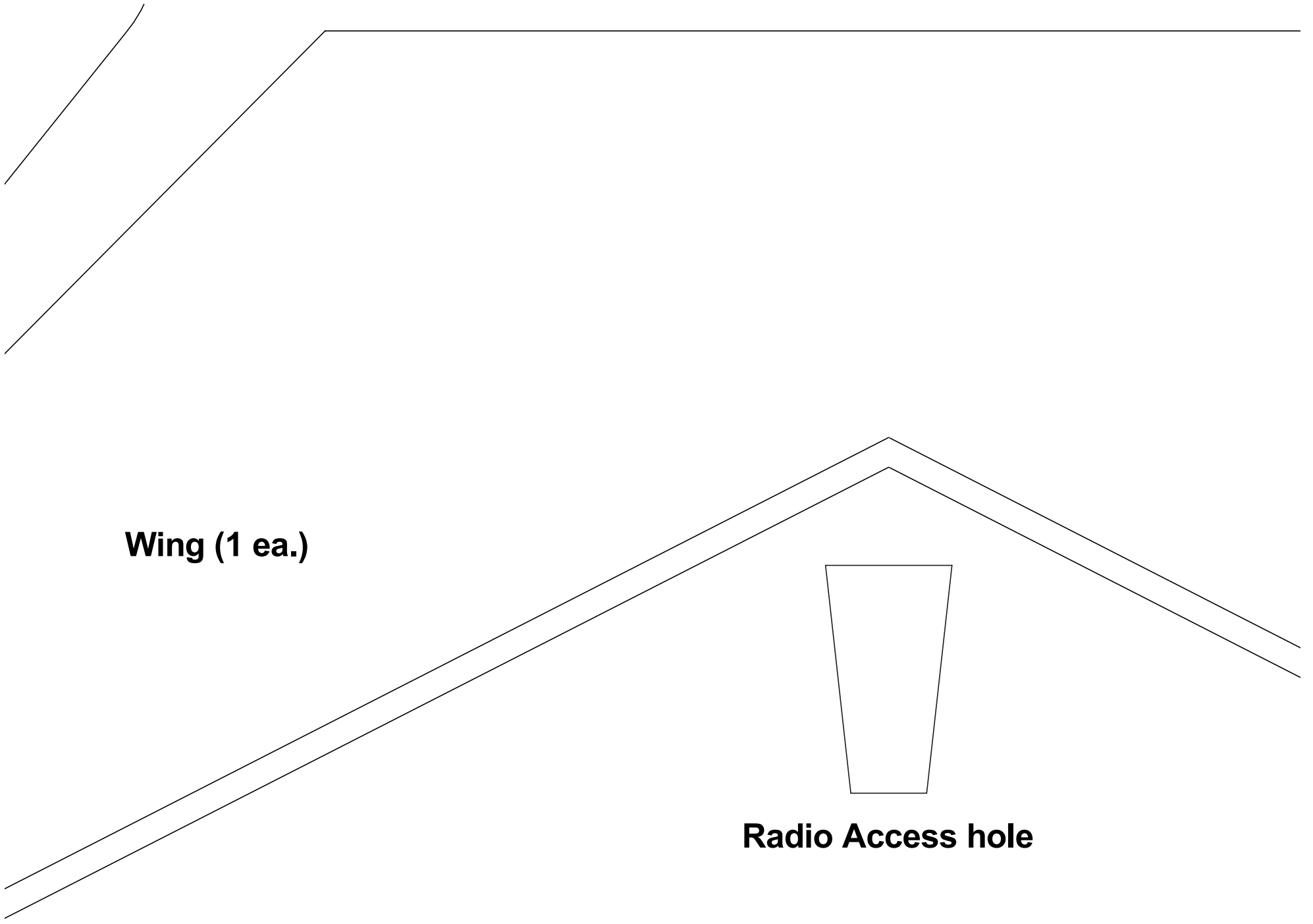

Wing (1 ea.)

Radio Access hole

(make 2 from 3 mm
Depron or 1/8" balsa)

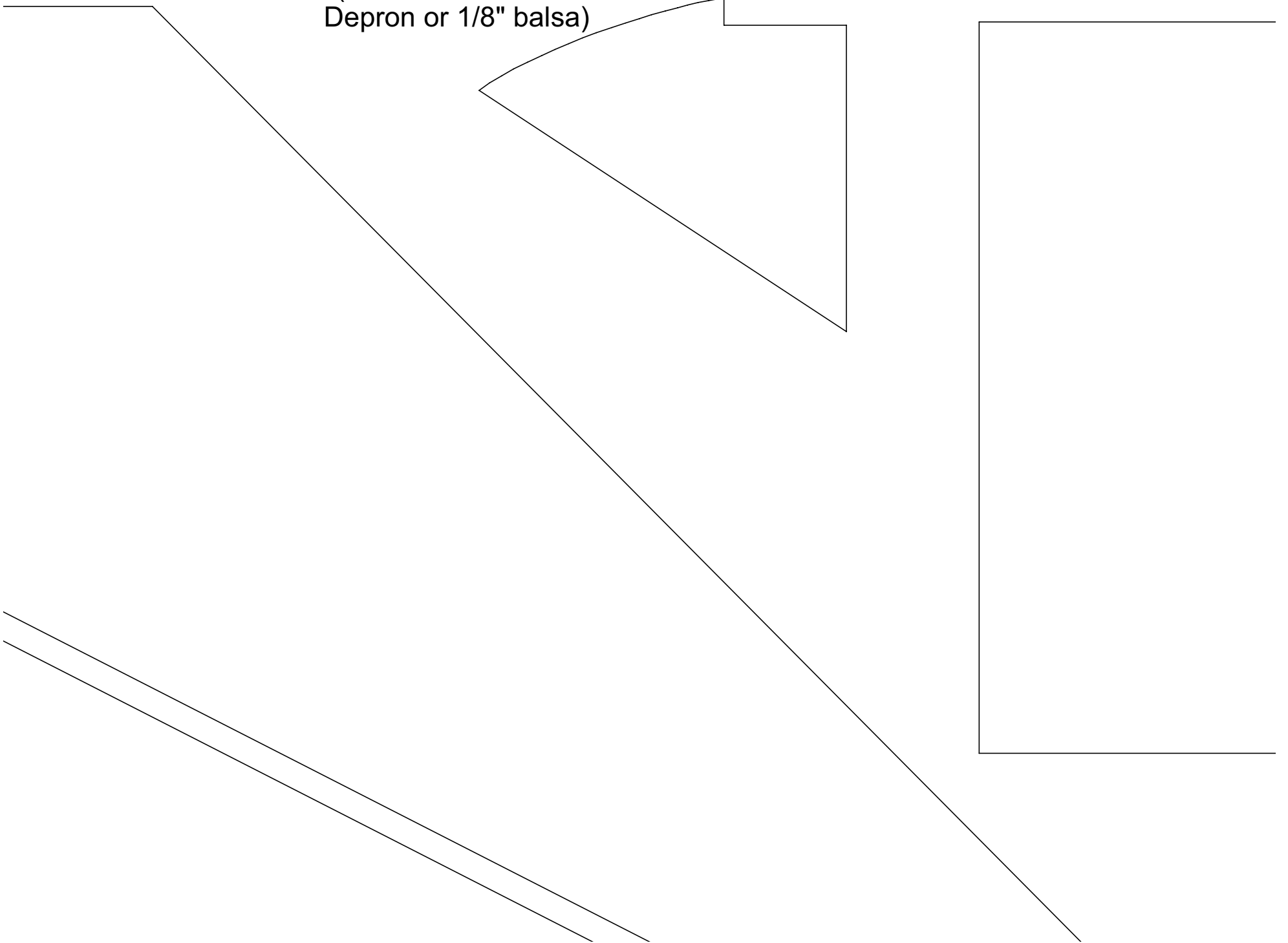

Aft Fuselage
Top (make 1)

Cut notch to fit
motor used

Forward inlet



—

|

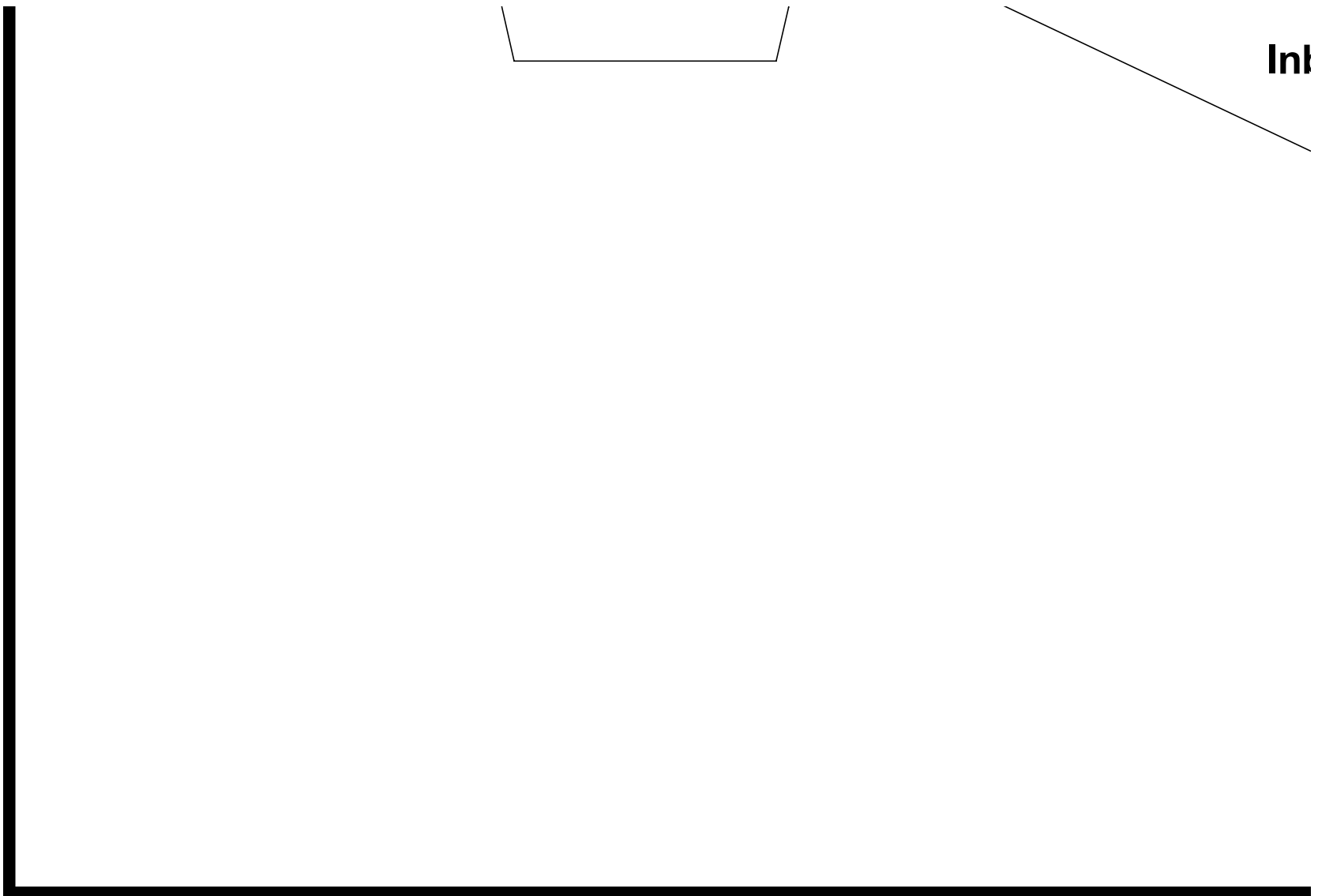

—

|

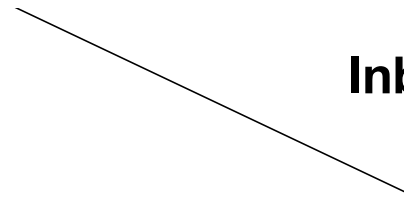
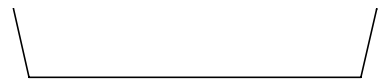

Int

—

|

—

board Inlet (2 ea.)

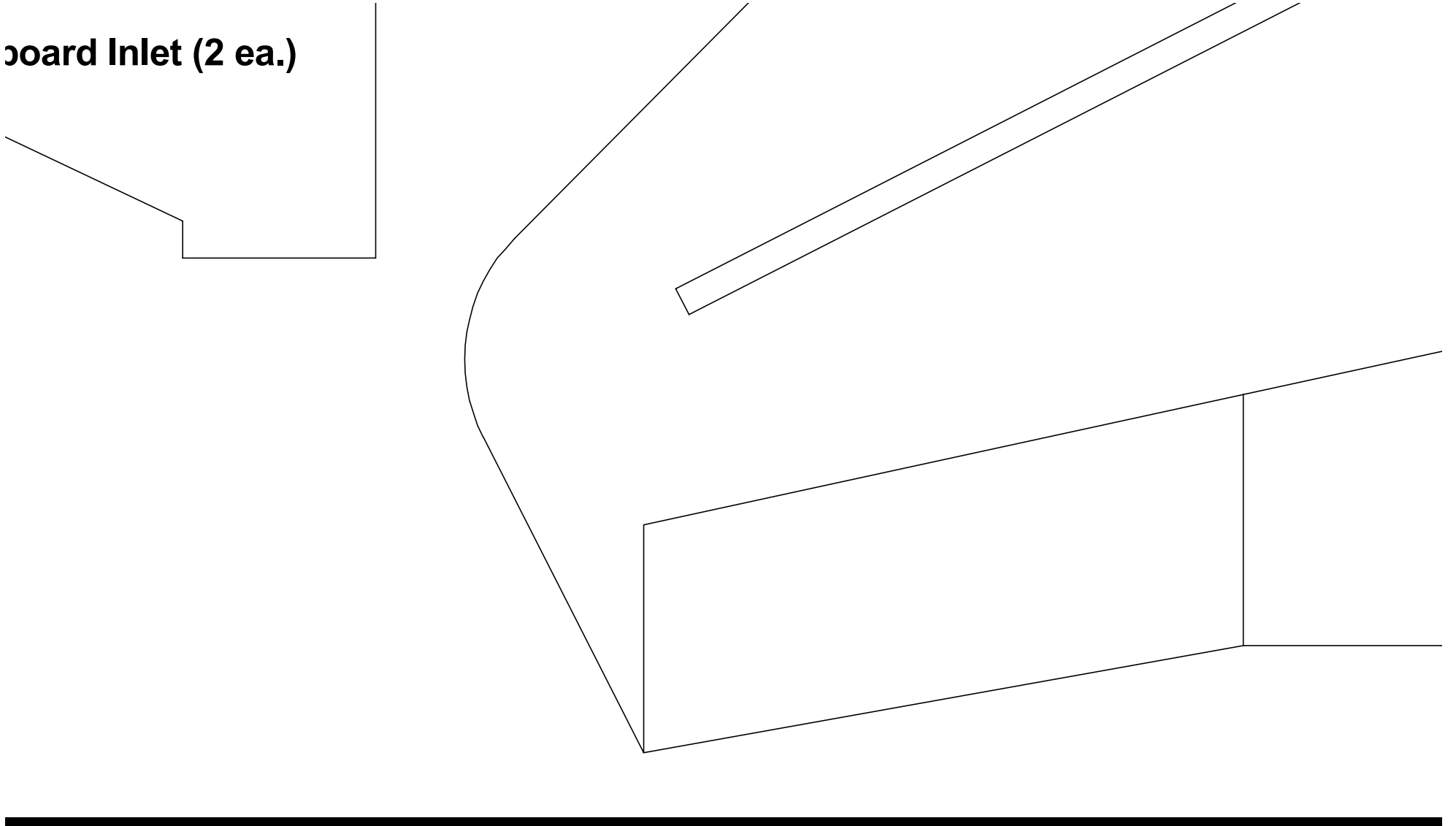

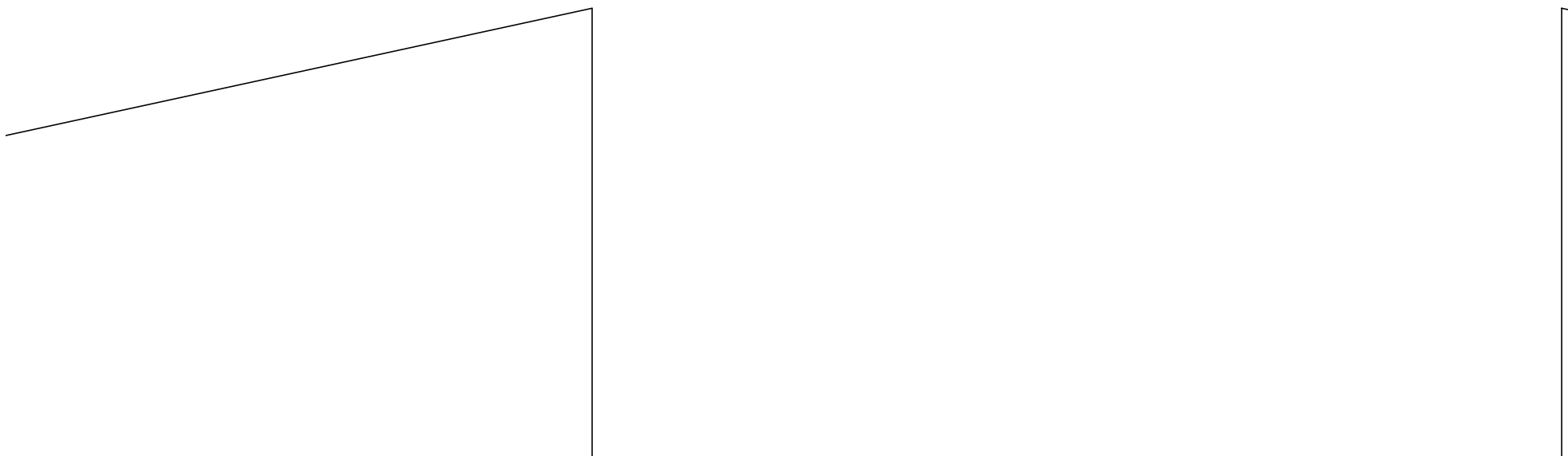

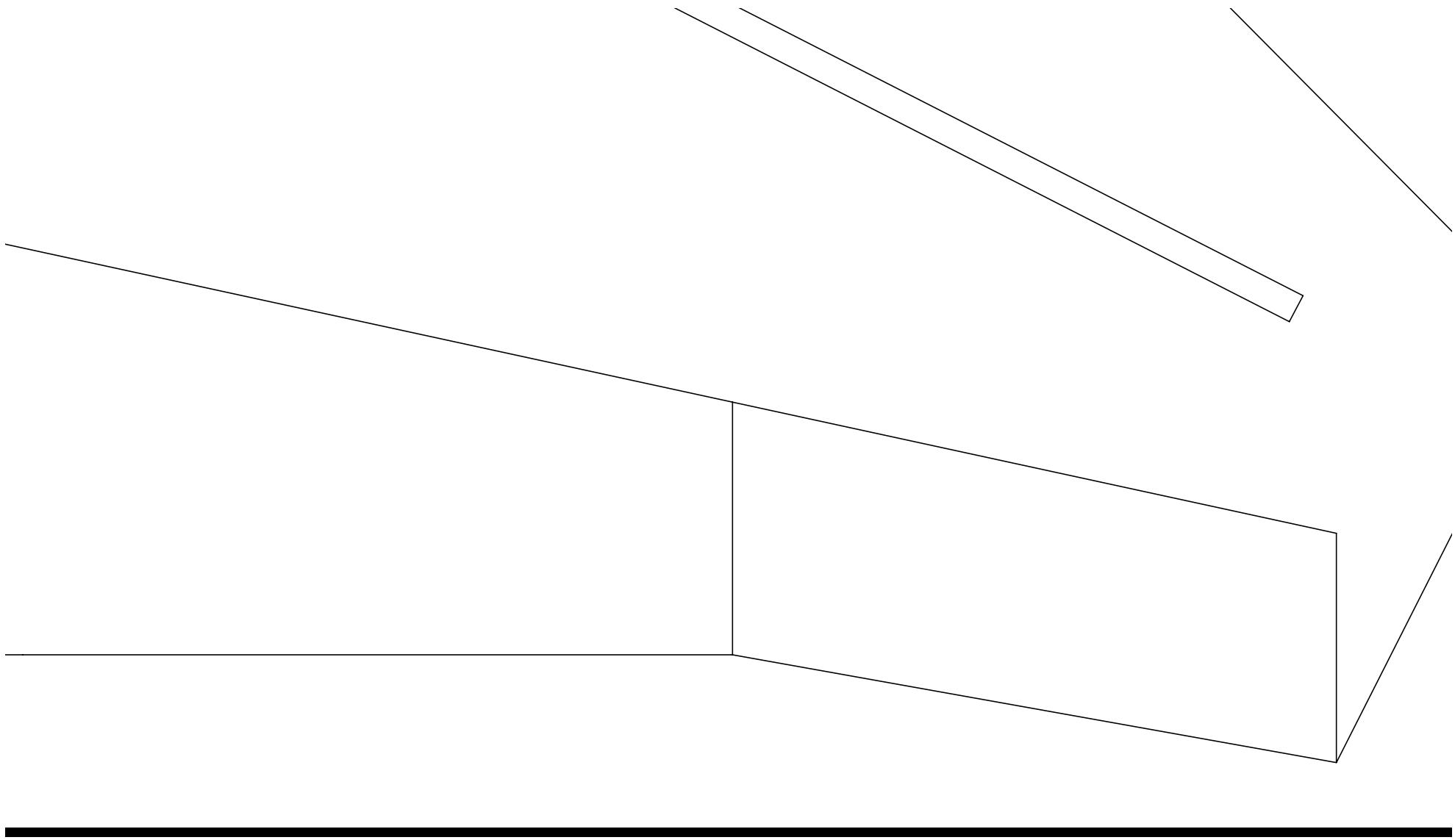

{Forward inlet
tops\P(make 2)}

Bevel this area

Exhaust nozzle
sides (make 2
mirror image)

Specs:

F-15 Park Jet

3D FOAMY

Copyright © 2004 3DFoam
All rights reserved.
Designed and Drawn by
Steve Shumate & Levi J
Updated: 0/19/2004

Weight	14-18 oz.
Thrust	14-24 oz.
Radio	4-5 Chanel
Area	289.7 in²
Loading	6.5-8.6 oz/ft²

WWW.3DFOAMY.COM

et

3DFoamy.com.
ed.
n by:
evi Jordan
4

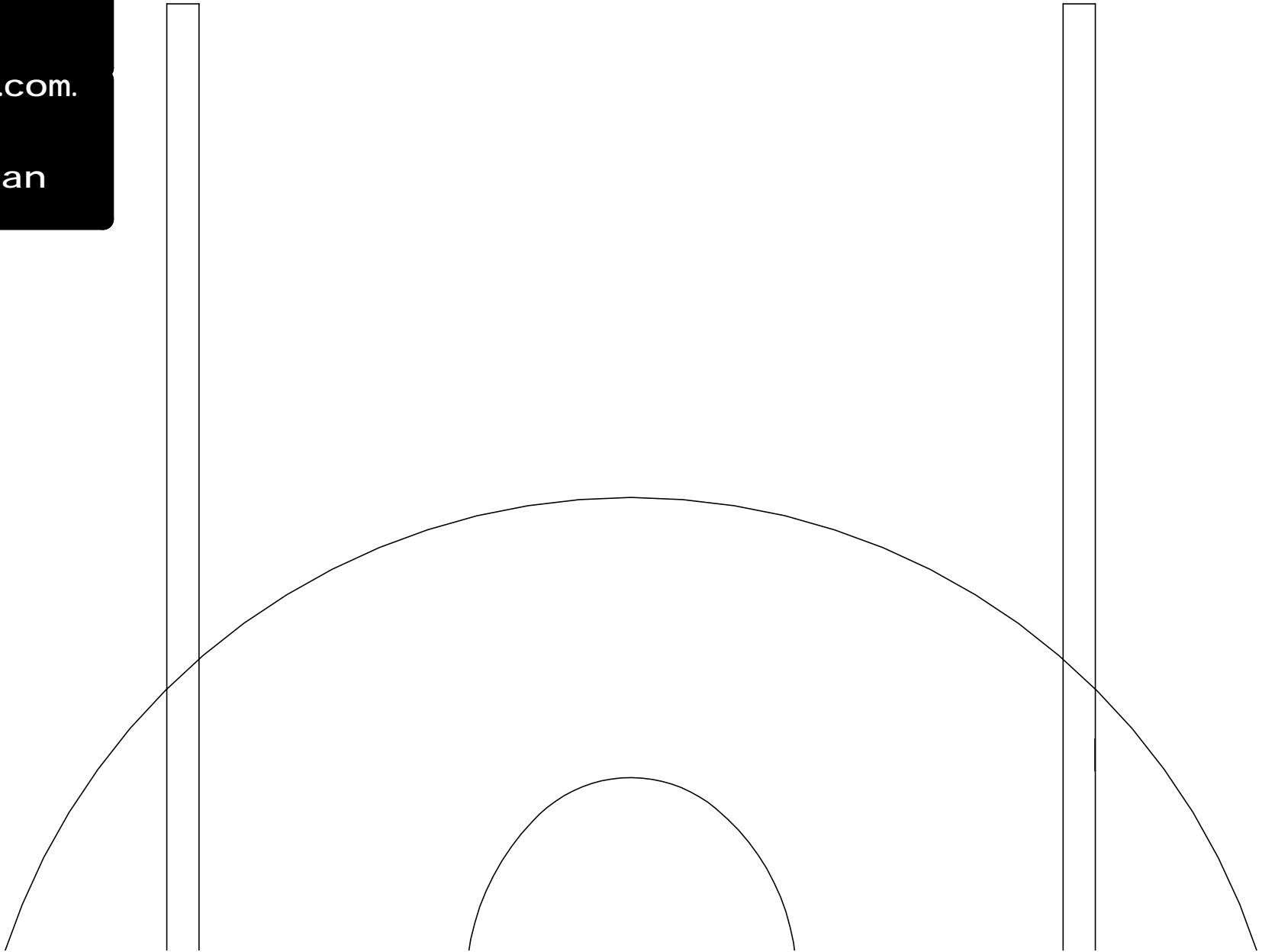

**Cut a "V" groove
in foam for
spars. Pull spar
through groove
to make round**

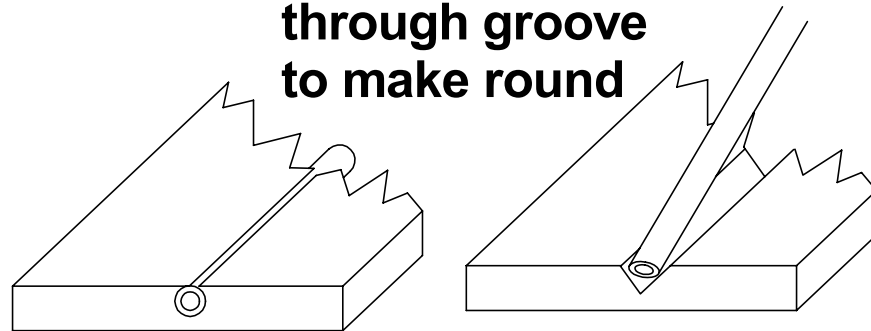

CG INFO

**Start with the recommended
CG range. You can adjust it
further back as you become
more familiar with the jet.**

**All hinging
tape or ac
points ep
and contr**

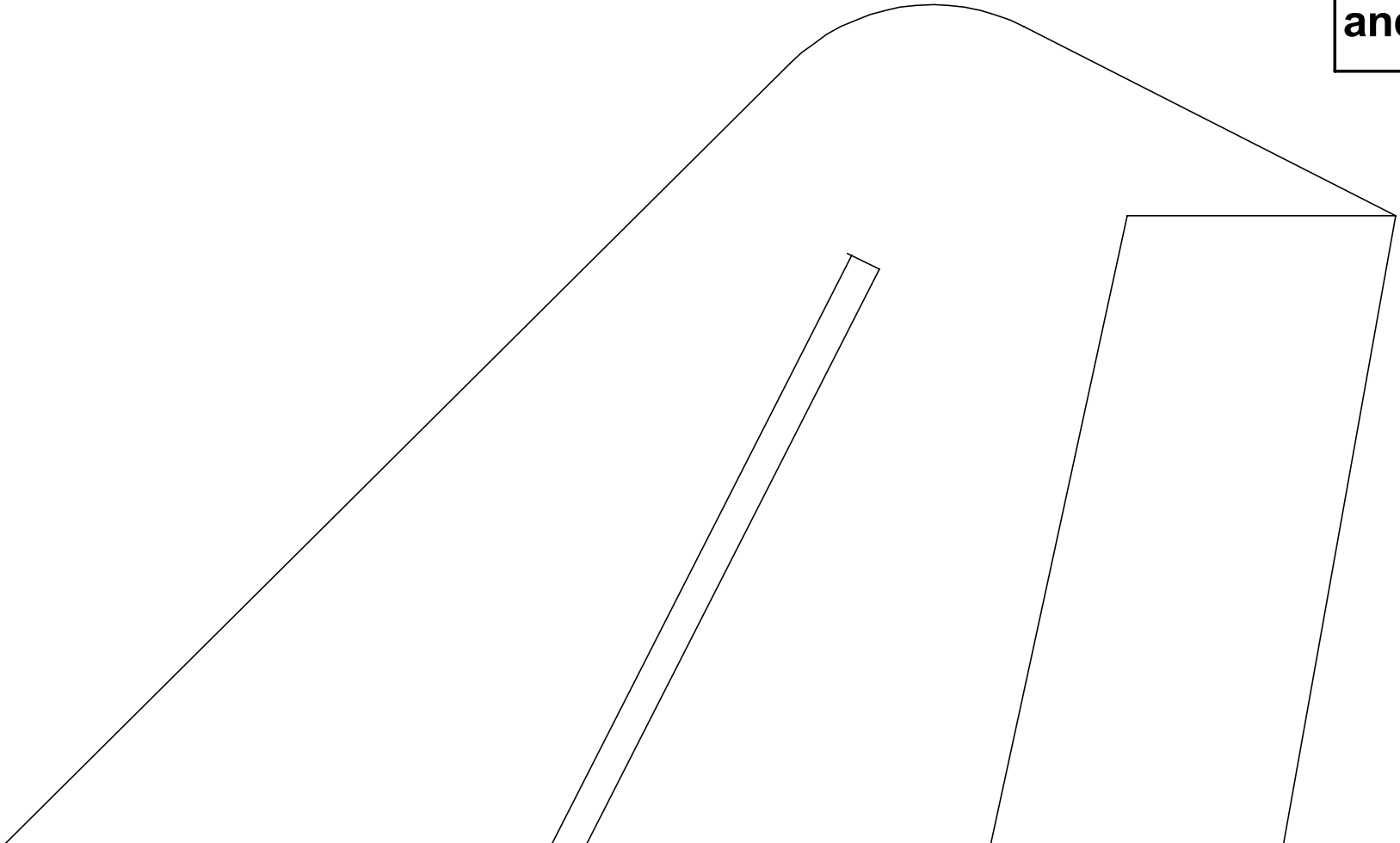

**ing for control surfaces can be packing
or actual hinges. I prefer robart hinge
epoxied in place for the added longevity
control freeness. CA hinges work well also.**

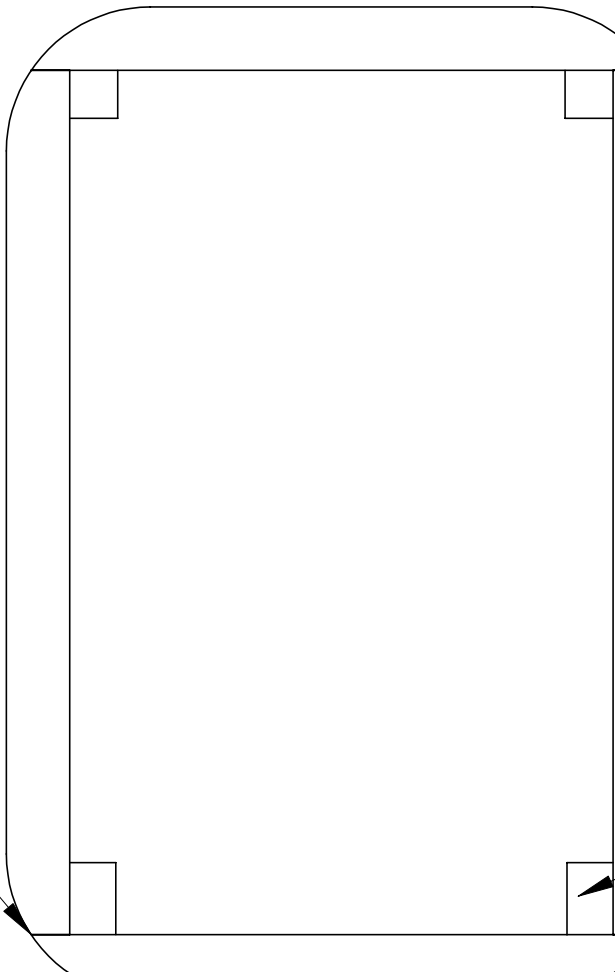
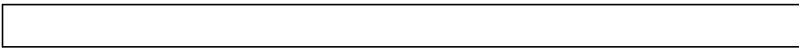
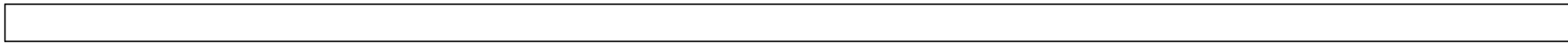

**Sand the fuselage corners round
with 80 grit sand paper,
then finish smooth with 200 and 400**

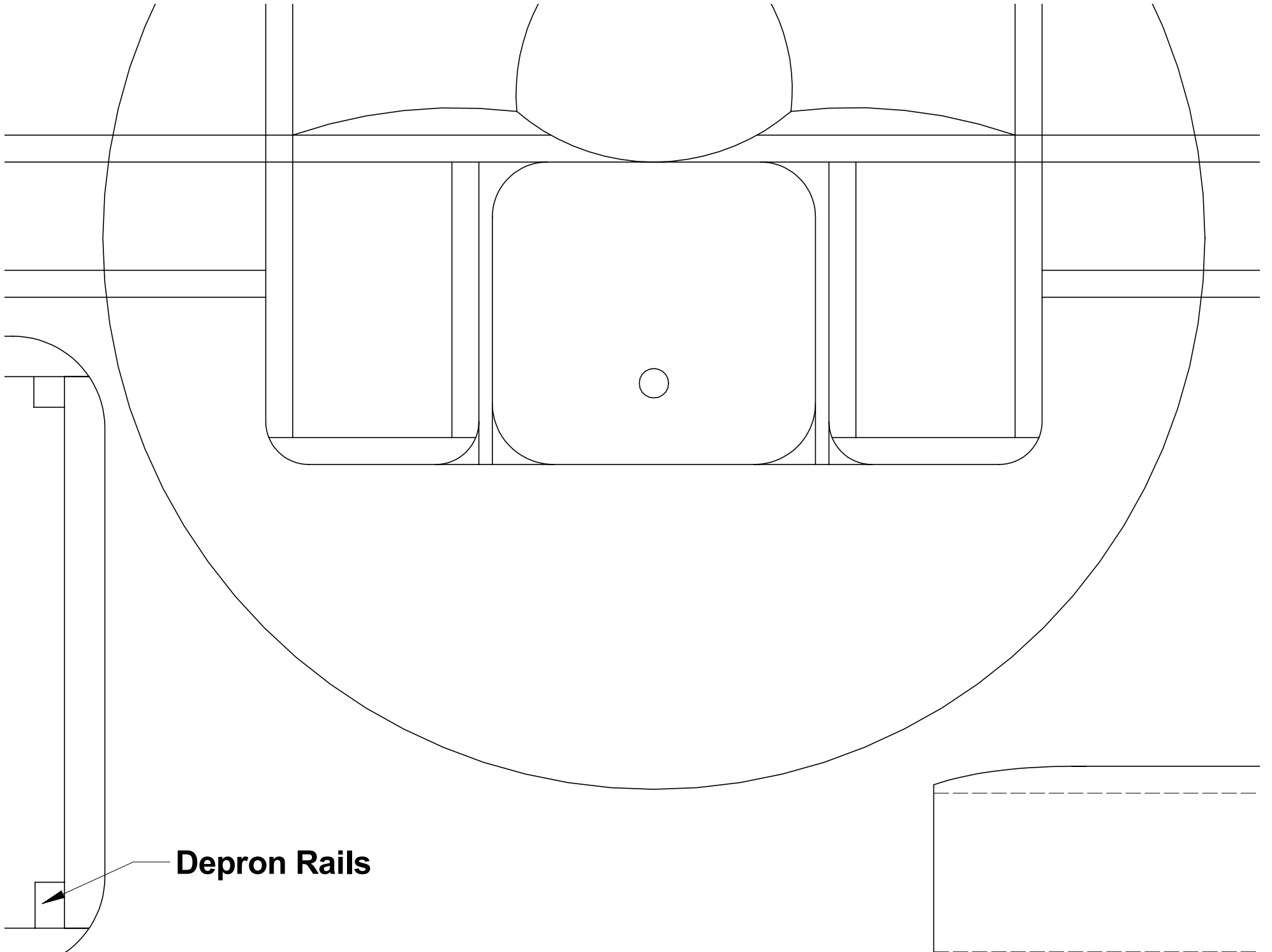

Depron Rails

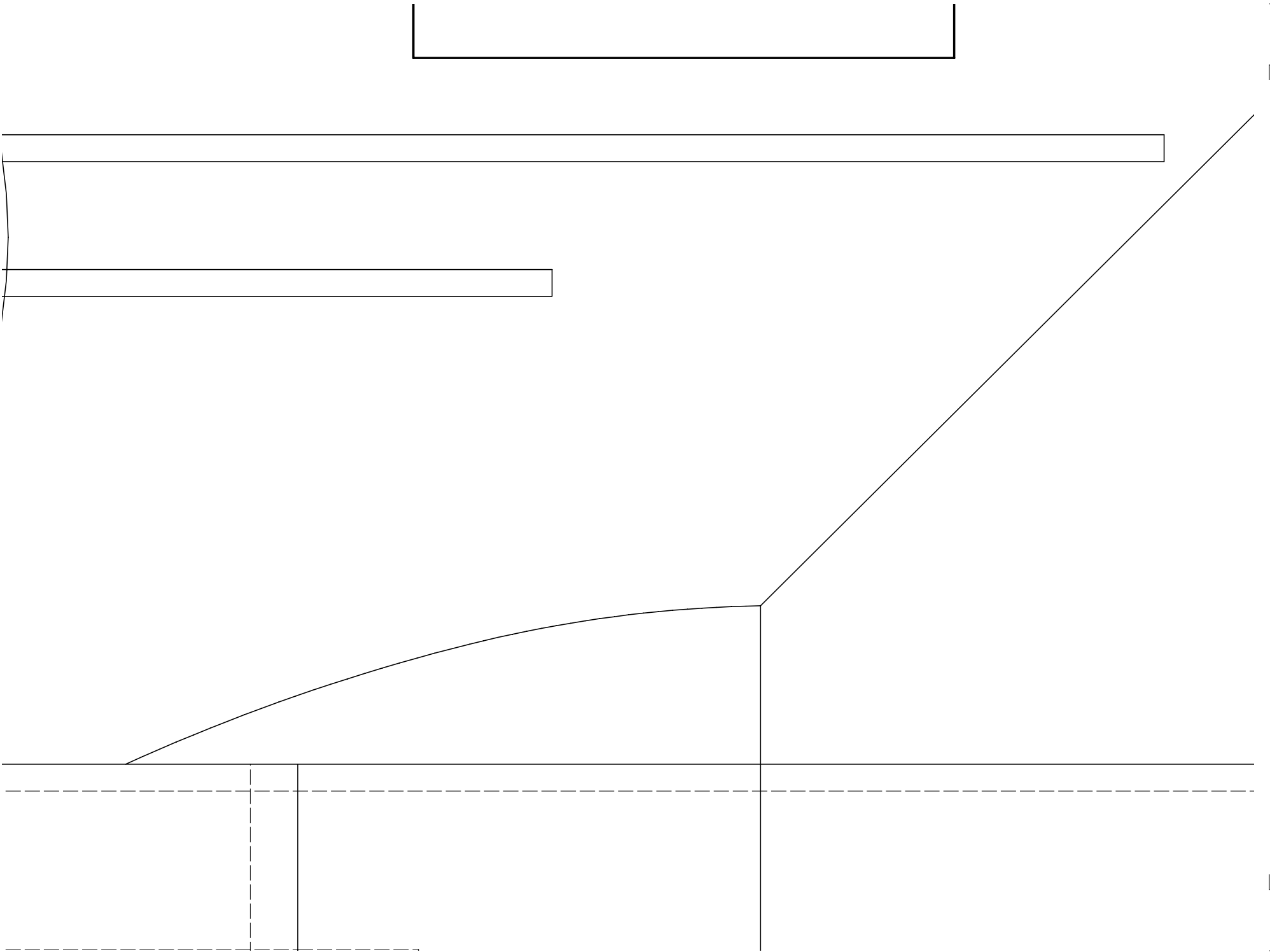

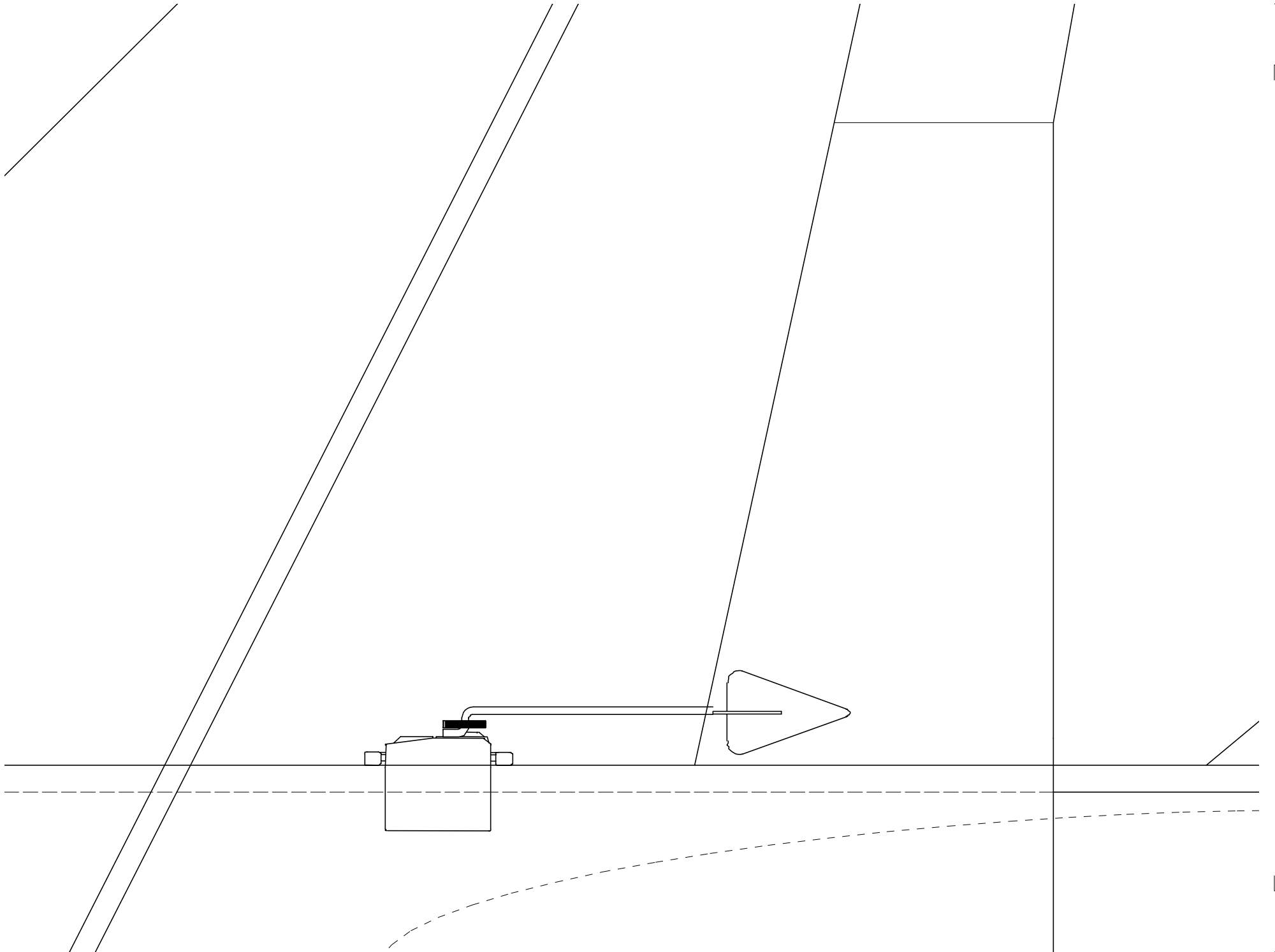

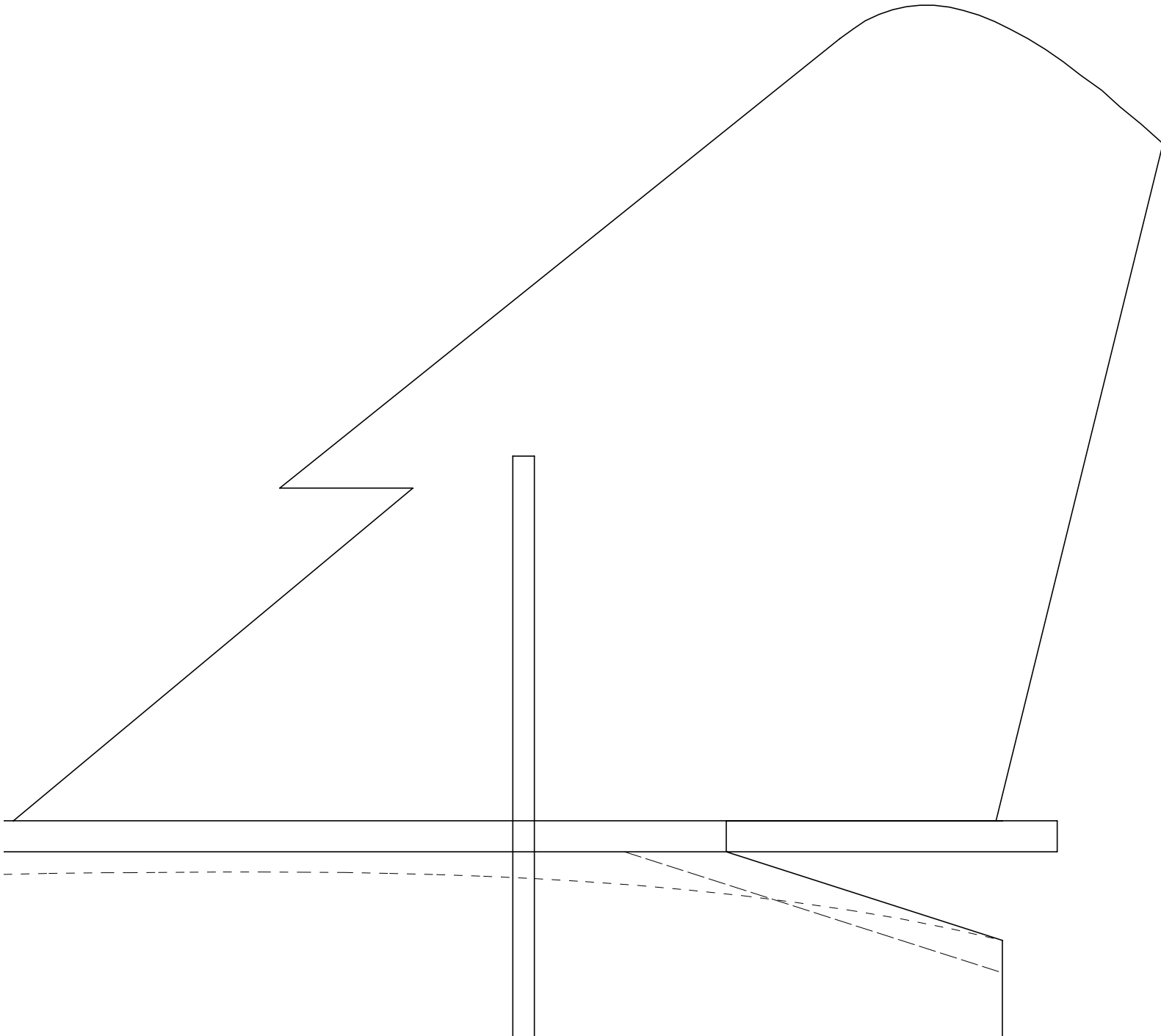

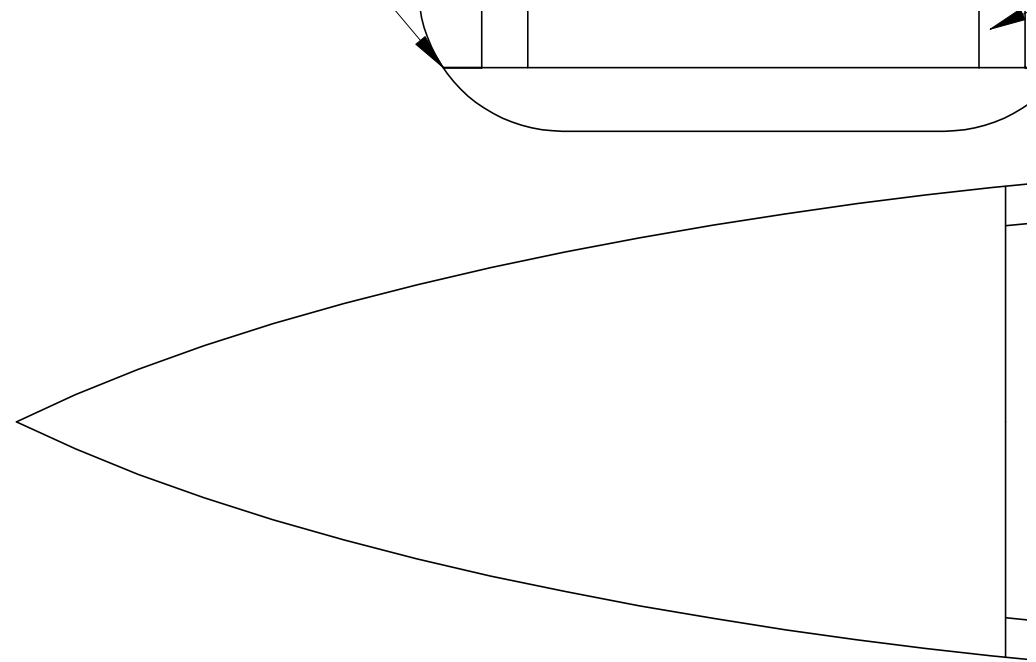

#1

Motor	Gearing	Prop	Batt Amps	Watts/lb	S thru
GWS EPS-350	5.33	8x6	9.7	93.2	✓
"	"	9x6	12.1	113.0	✓
Himaxx 2015-4100	4.43	9x6	11.6	108.7	✓
"	"	9x7	12.4	115.8	✓
"	3.75	9x6	14.2	129.2	✓
"	"	9x7	15.0	135.0	✓
Himaxx 2015-5400	5.33	9x6	12.9	118.7	✓
"	"	9x7	13.8	126.1	✓

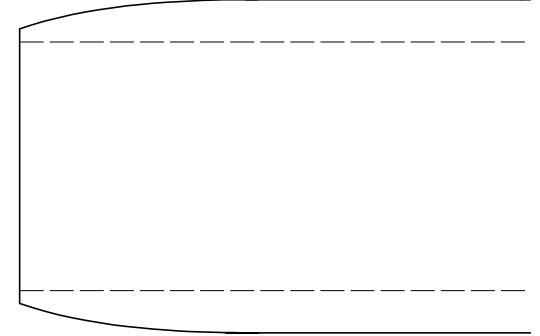
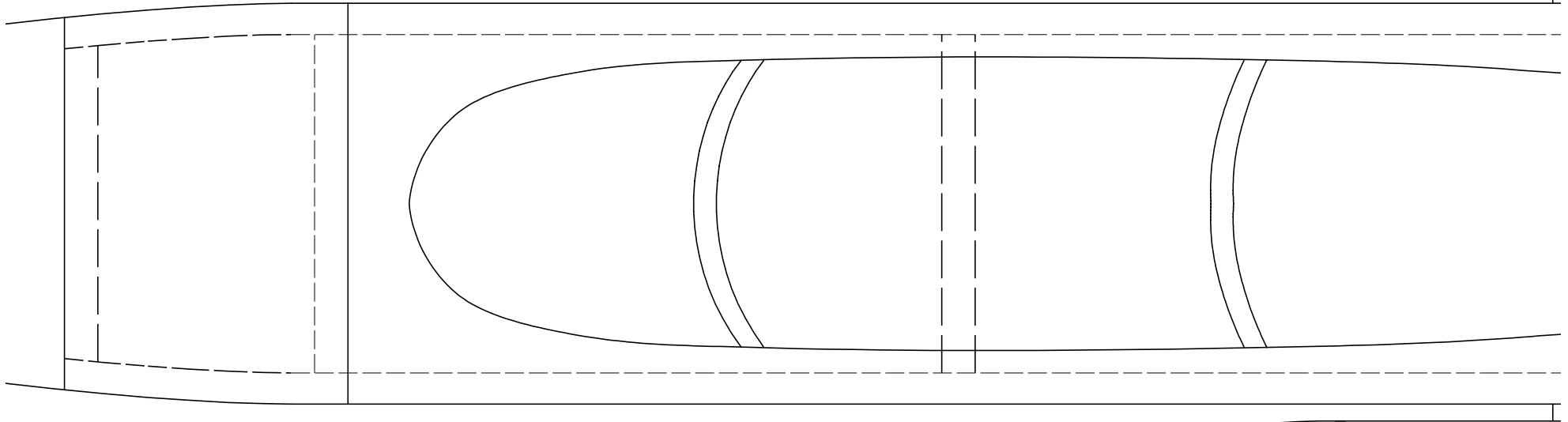
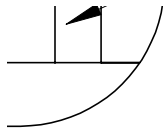

Static thrust, oz	Pitch speed, mph	Comments
14.4	48.7	Max amps and watts with GWS brushed motor for reasonable life
18.5	43.4	VERY hard on motor
18.9	43.8	Pitch speed slow
18.3	49.2	Great combo
20.0	45.0	
18.9	50.0	
20.0	45.0	
19.2	50.5	Great combo

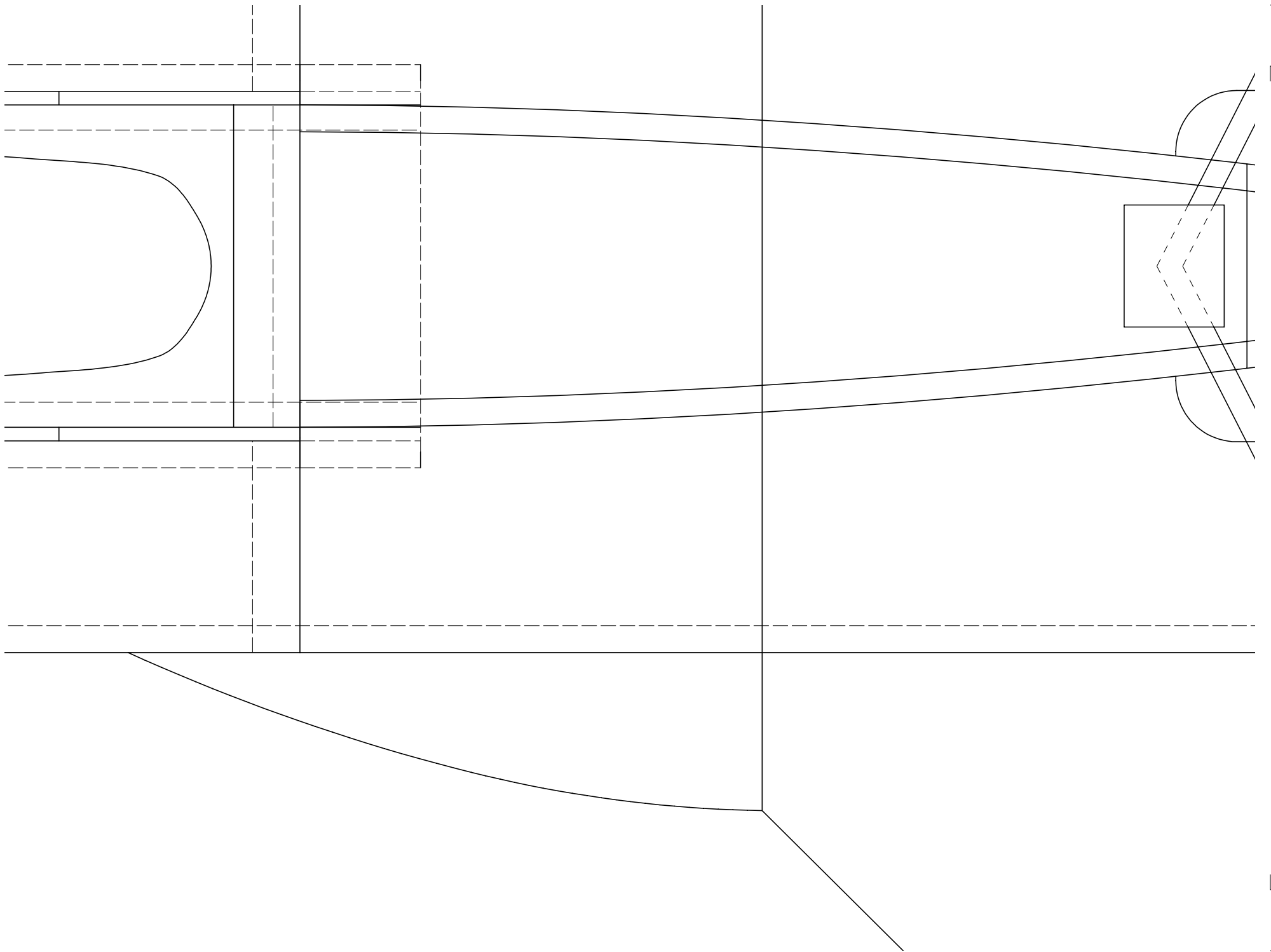

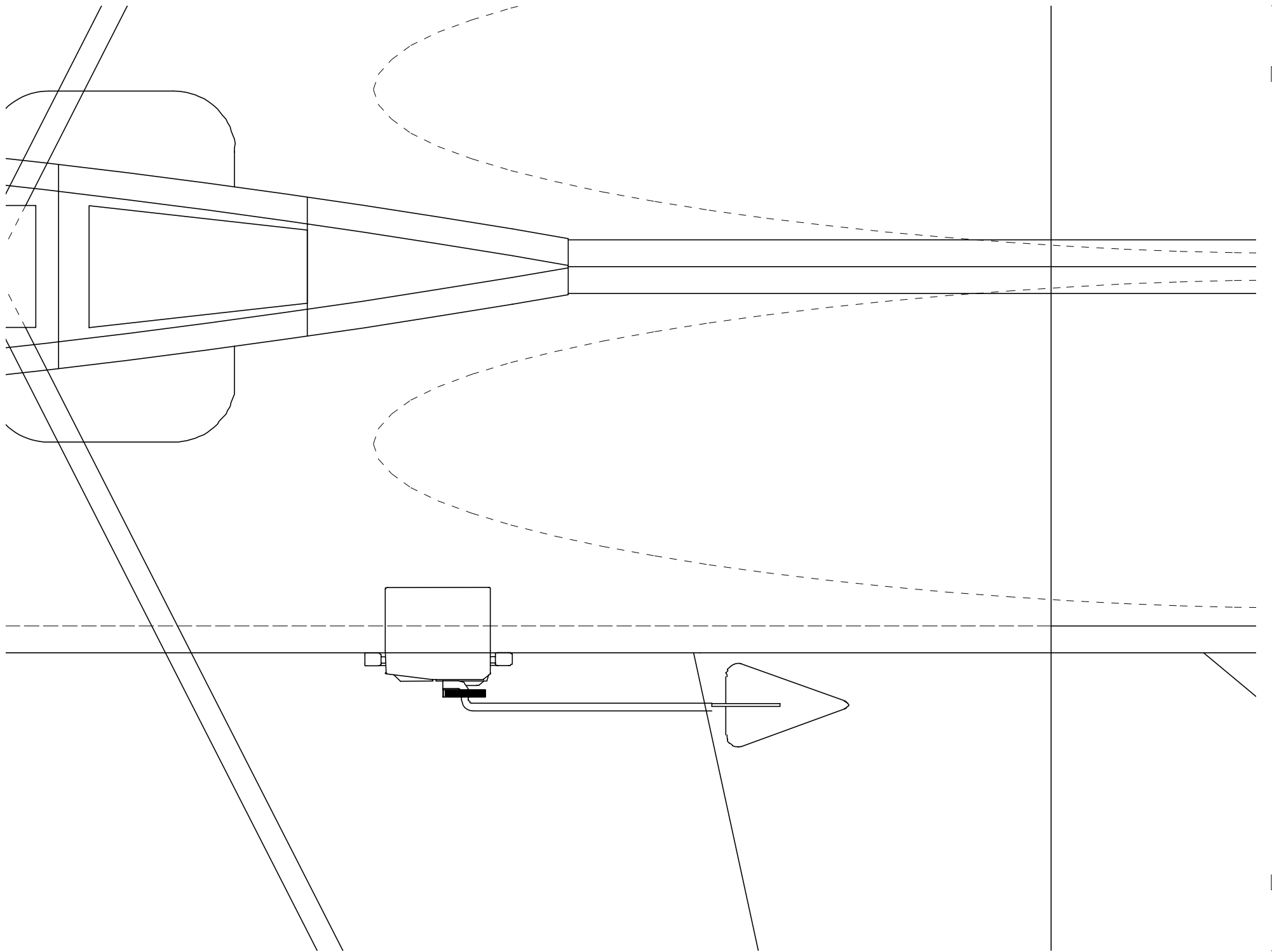

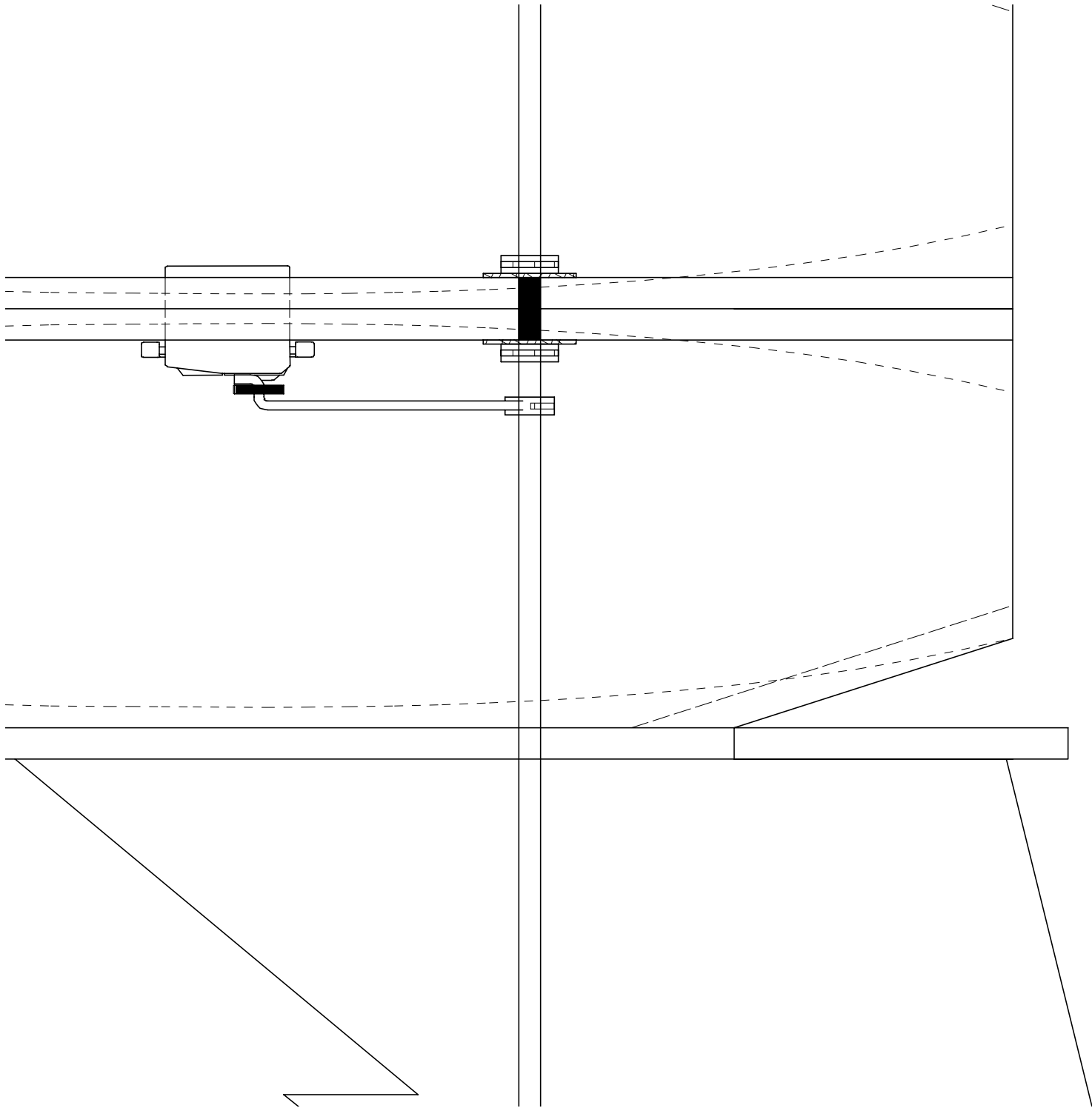

5400	5.33	9x6	12.9	118.7	
"	"	9x7	13.8	126.1	
"	4.43	8x6	13.4	122.7	
Axi 2212/20	NA	8x6	13.6	124.5	
"	"	9x6	15.4	138.3	
Mega 16-15-5	Direct	6.5x4	15.3	126.1	
Razor RZ350	4.43	8x6	9.2	89.1	
"	"	9x7	13.2	122.7	

Prototype Setup/Specs

Wing area: 289 sq in (effective area, which includes)

Span: 28.4 in

Length: 41.7 in

Weight RTF: 15.6 oz as shown

Wing loading: 8.2 oz/ft² (based on effective wing area)

Motor: GWS EPS-350 with "C" gearing

Battery: 11.1V 1200 mAh Lipo

Prop: GWS 8x6 SF

Current draw: 9.7 amps

Power loading: 101 watts/lb

Radio equipment: GWS R-6 receiver, GWS Pico 2

Flight controls: Wing flaperons, full-flying horizontal

Materials used: Either 6mm Depron or BlueCore

6
5
4

20.0	45.0	
19.3	50.5	Great combo
17.1	53.1	
15.6	51.3	
18.2	43.3	Pitch speed slow
17.7	56.9	
14.7	49.2	Least current for good performance
19.7	51.1	Great combo

S

includes the effect of the wing strakes)

wing area)

**ico and Hitec HS-55 servos, 10 amp ESC
 orizontal stabilizer, twin rudders
 core fan fold foam**

Round LE, apply 3M 1" Satin tape for protection

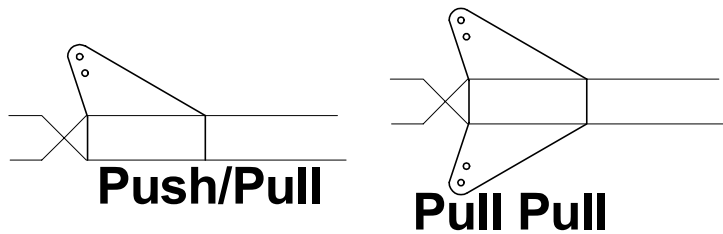

Push/Pull
Pull Pull
Cut Control horns from 1/32"
ply or a plastic coffee can lid.

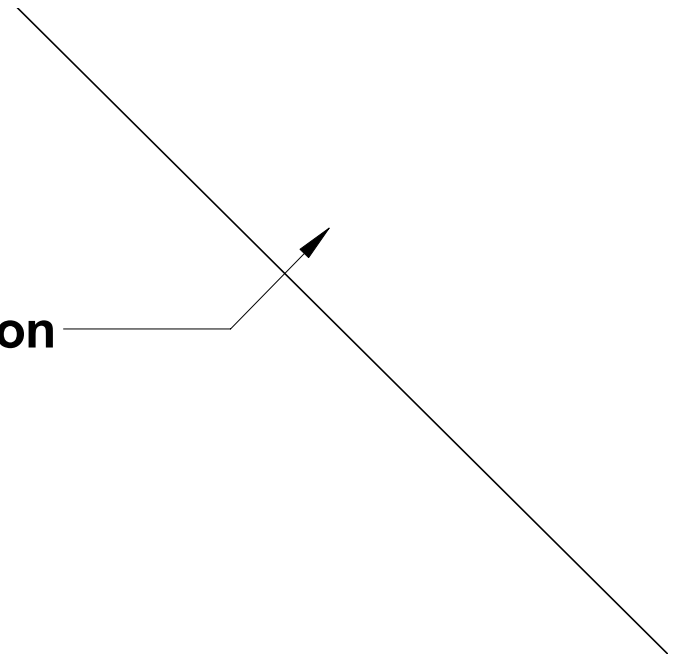

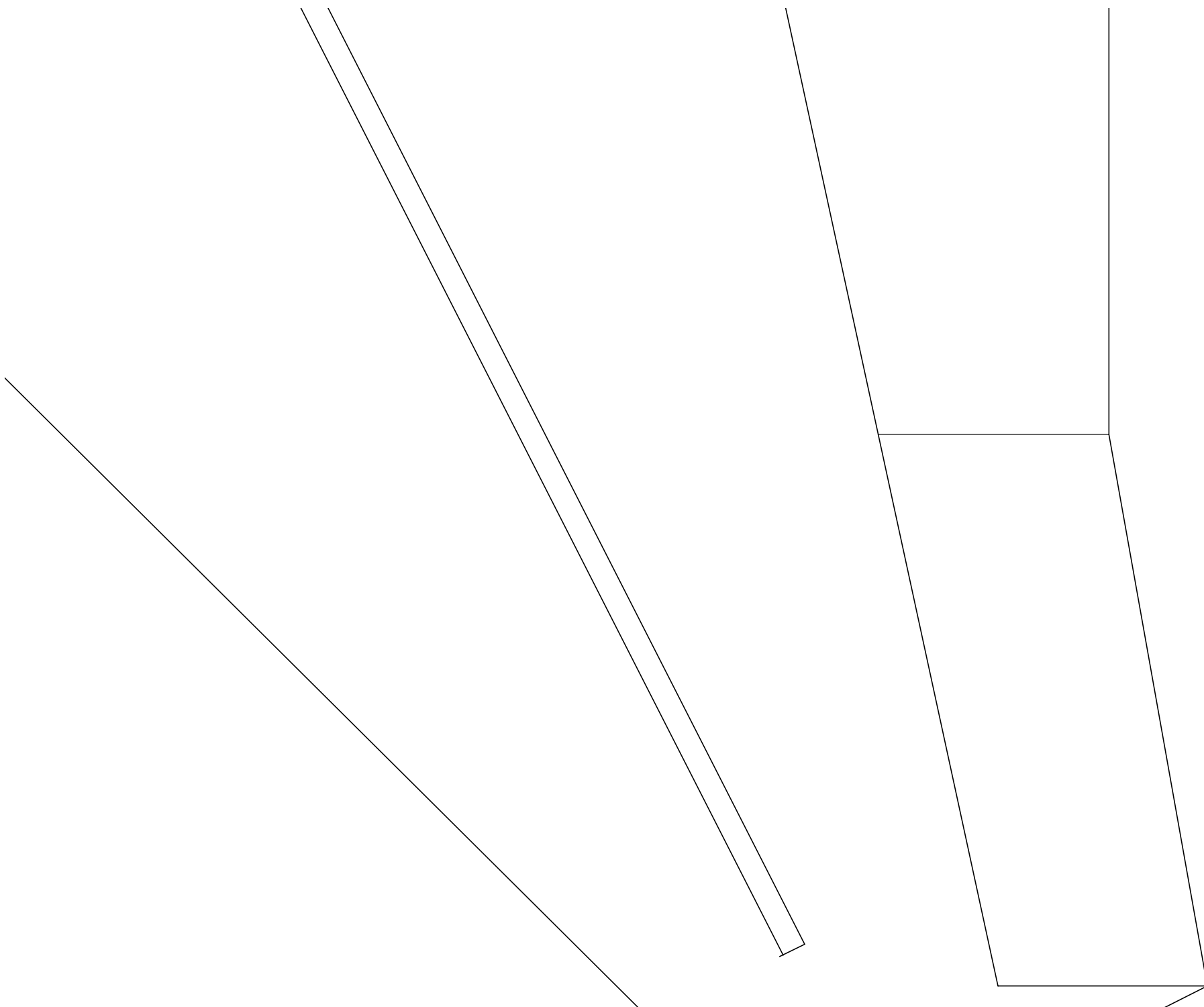

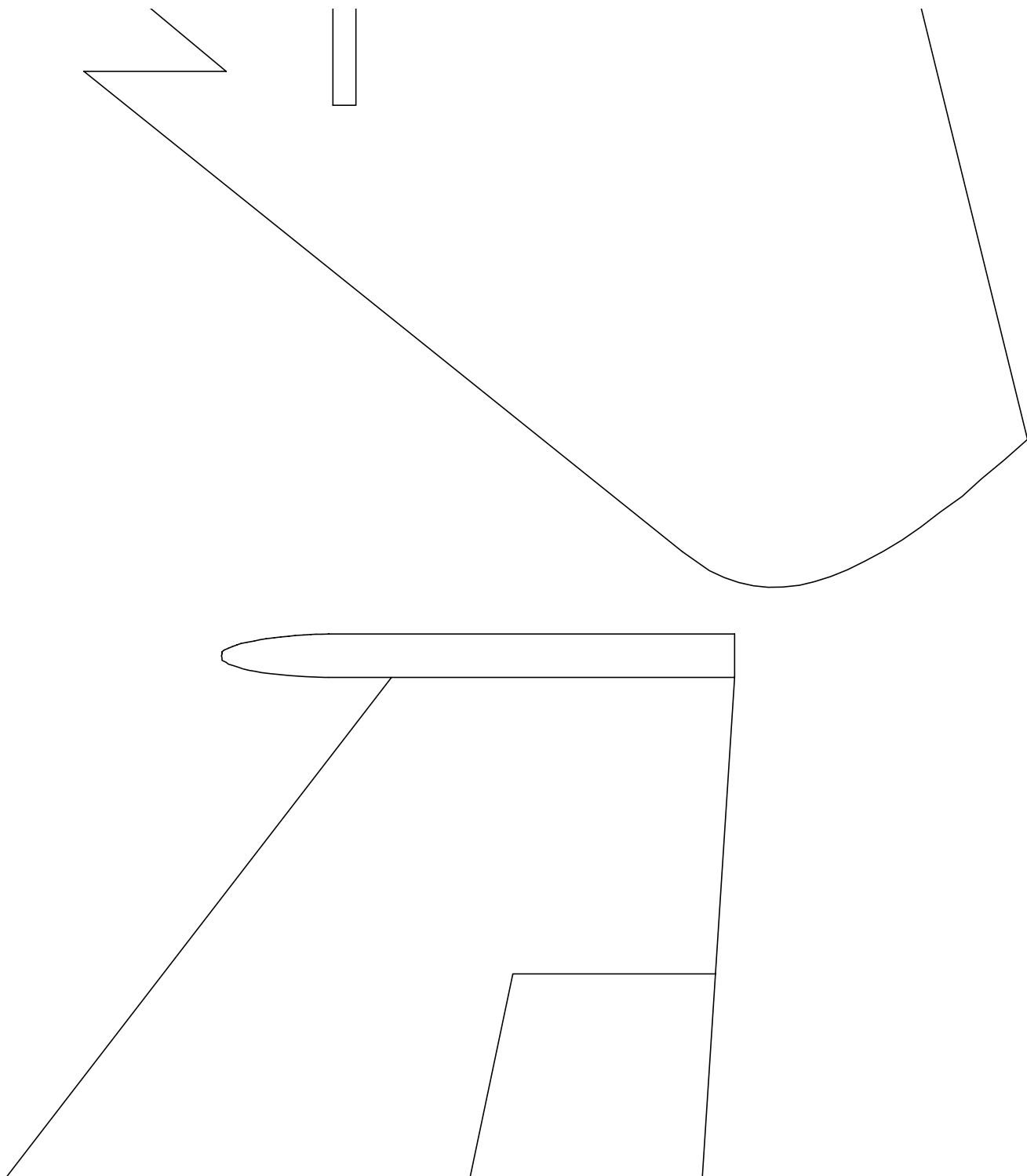

Flight Controls: Wing Paperons, Roll-Over Protection
Materials used: Either 6mm Depron or BlueCore

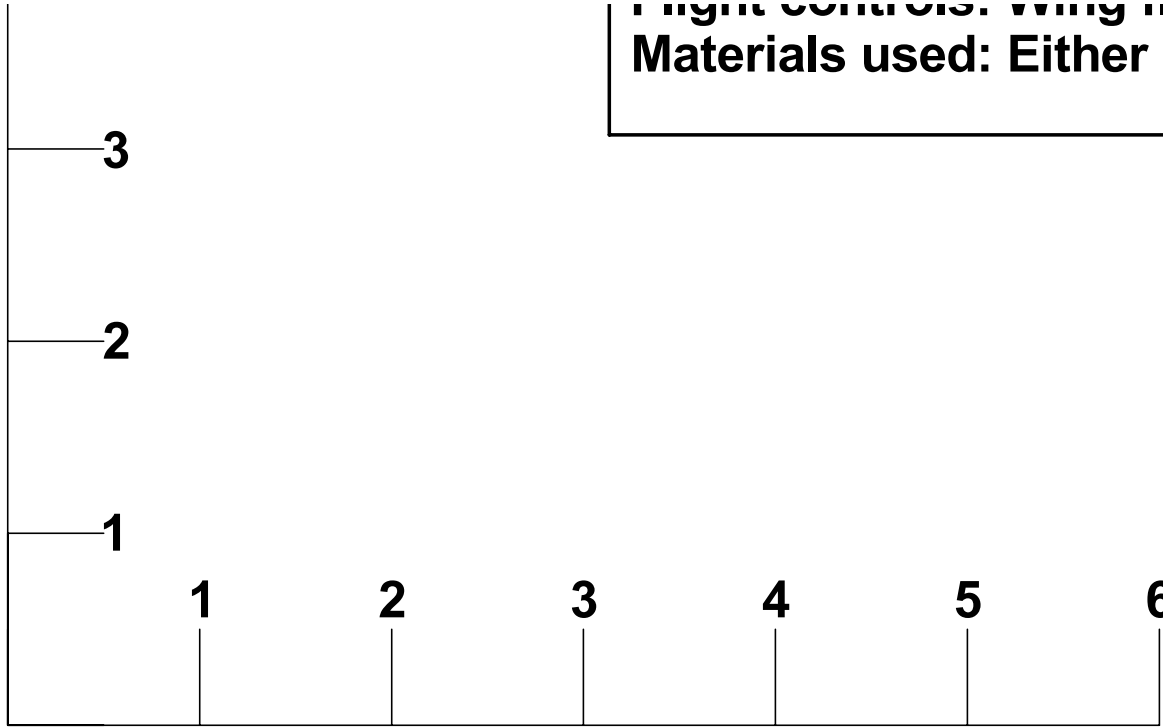

**Foam Nose Cone
(CNC Cut, Sanded to shape)**

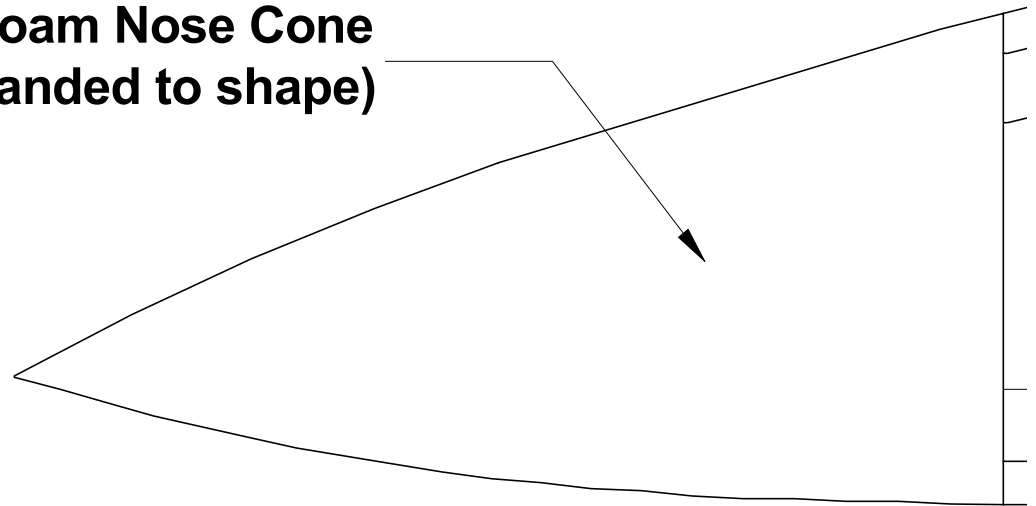

**Horizontal stabilizer, twin rudders
Core fan fold foam**

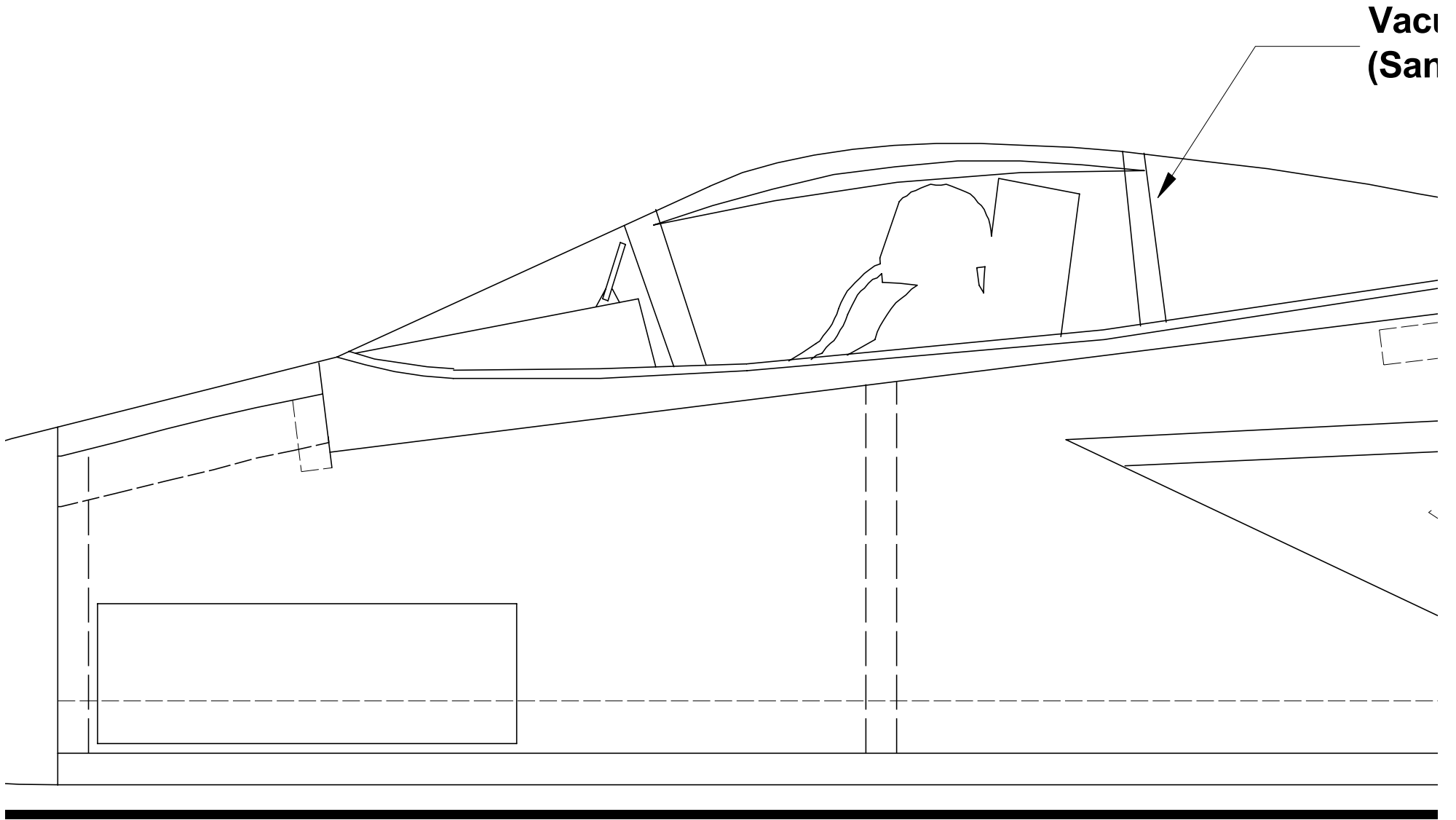

**Vacuum Formed Canopy
(Sand from foam if scratch built)**

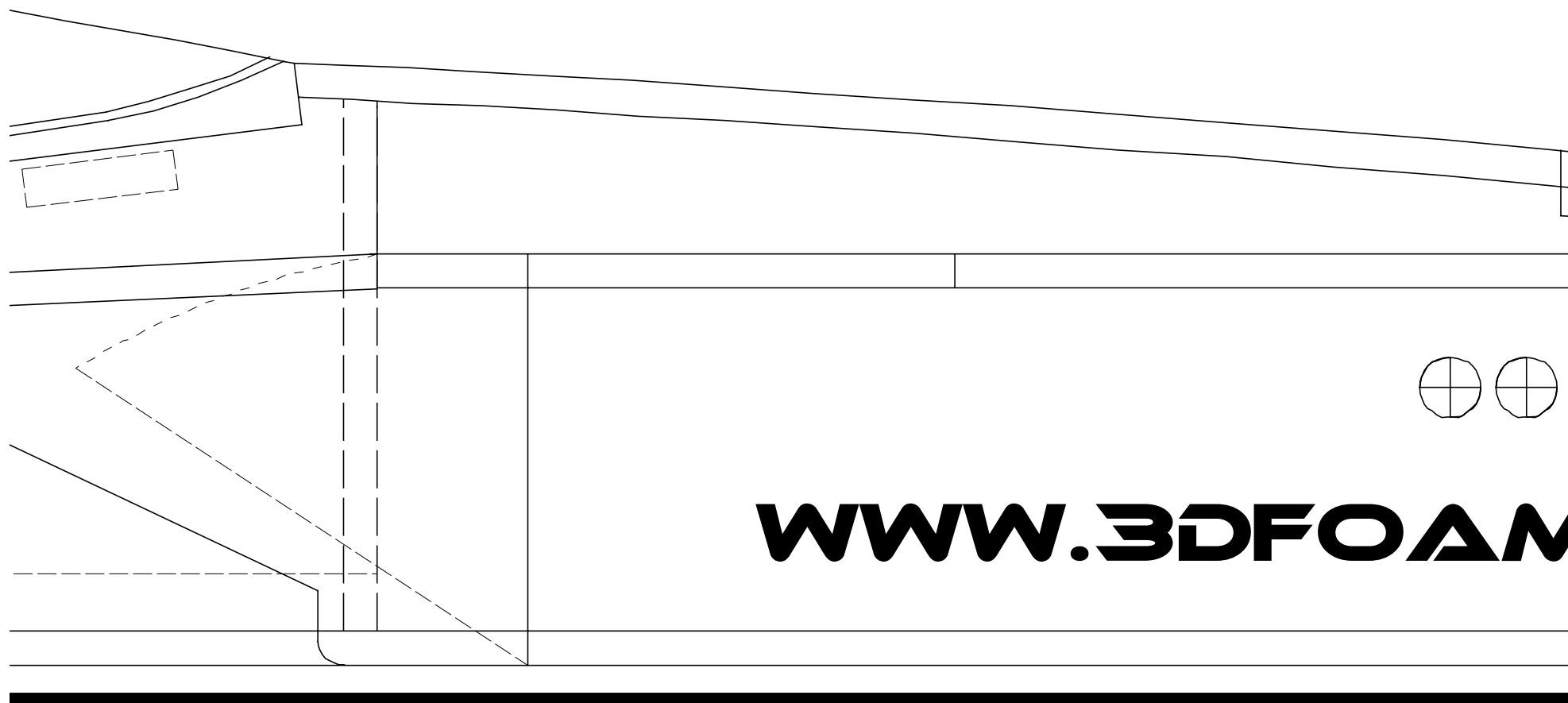

WWW.3DFOAM



**Cut hatch after painting
for radio access**

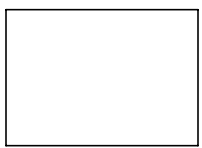

MY.COM

**Laser cut 1/4" birch motor block.
Epoxy into plane. DO NOT use
CA on the motor mount.**

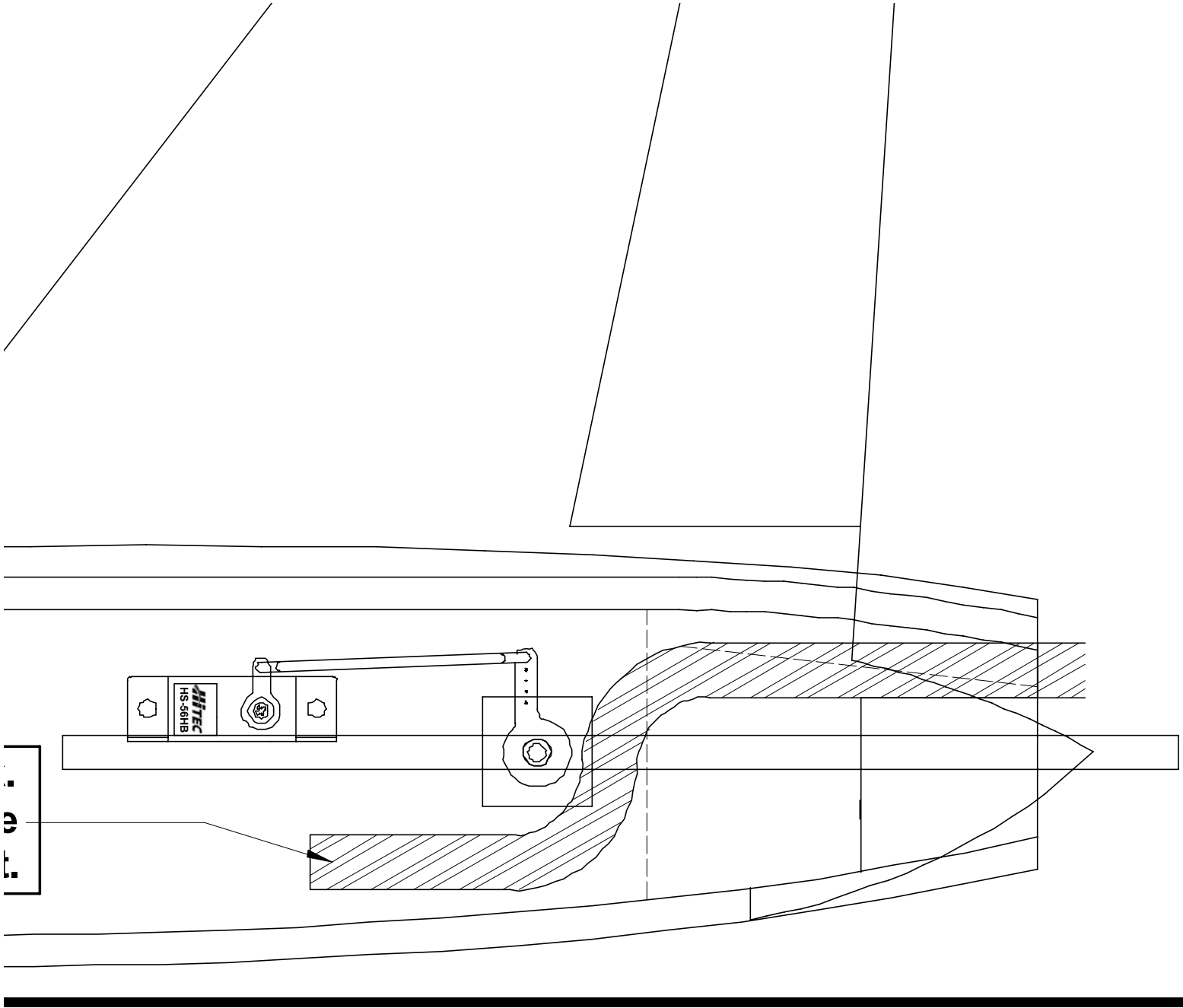

1 0 1

3D FOAMY

F-15 Park Jet



Made In Washington State, USA!

Kit# 3DF017

A High Performance Electric Jet

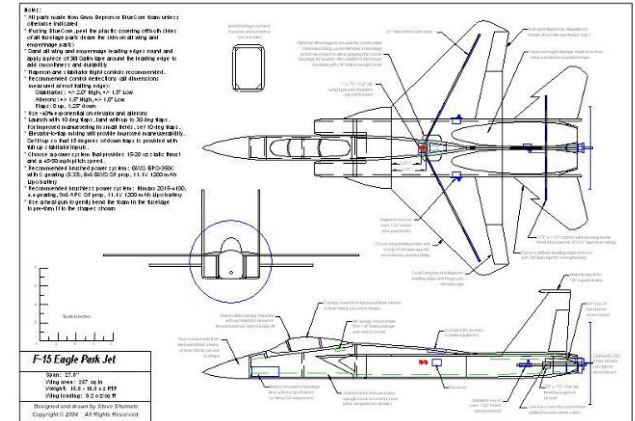

About This Construction Manual

This booklet divides the construction into sub-assemblies; wing, fuselage, etc. **Please read each section carefully before starting on that particular sub-assembly.** There is a complete description of all parts under "Kit Contents" Please check to make sure your kit is complete. We are human, and occasionally miss something! If you have trouble identifying a part, or are missing something, please contact us and we can help.

During the construction process the steps will outline what part to use. We have used actual pictures instead of unclear or often inaccurate illustrations to assist in the building process. This manual was intended for English users, and all measurements are made in standard units. (Inch, foot, etc.)

Customer Service:

Should you experience a problem building or flying this kit, we recommend you see your hobby shop first. If you are unable to solve the problem, feel free to write:

3D Foamy (Levi Jordan)
10040 West Barberry
Cheney, WA 99004

help@3DFoamy.com or online at www.3DFoamy.com

This product is sold with exclusion of all warrantee, expressed or implied, statutory or otherwise. Pilot assumes all risk in building and operating this model. Do not operate if you are not an experienced modeler. Refer to and abide by AMA rules at www.modelaviation.com for regulations on Radio Control Models.



Kit Contents

Part No.	QTY.	Dimensions	Description
007201a	1	Laser Cut Foam	Foam Kit Parts A
007201b	1	Laser Cut Foam	Foam Kit Parts B
007202	2	.21" dia carbon tube	Wing Spar
007203	1	.157" carbon tube	Stabilator spar/pivot
007204	1	4" x 3/8" x 3/8" hardwood	Motor mount
007205	3	1/64" plywood squares	Stabilator supports
007206	2	1/32" plywood squares	Wing spar doublers
007207	4	1/32" plywood elbows	Vertical tail supports
007208	3	3/16" aluminum tubing	Stabilator pivot bearings
	1	CD ROM	Instruction/Plans CD
007209	1	Laser Cut Plastic	Control Horns/Doublers
007210	1	Intro Sheet	Getting Started Paper

Additional items you will need

<input type="checkbox"/> 4-5 Ch radio system with 4 micro servos and mini or micro receiver (HS-55 or similar)	<input type="checkbox"/> GWS "C" type gearbox which has a 5.3:1 ratio	<input type="checkbox"/> Props - A GWS 8x6 prop is recommend for brushed motors
<input type="checkbox"/> Odorless Medium CA and accelerator. (Accelerator a must)	<input type="checkbox"/> Connectors – Dean’s Ultra connectors are recommend for this model.	<input type="checkbox"/> Speed Control - Castle Creations Pixie 20 brushed motor speed controller or equivalent
<input type="checkbox"/> 5 or 15 minute Epoxy	<input type="checkbox"/> Li-Poly Battery pack (1200-1500 mah 3s1p recommended)**	<input type="checkbox"/> Li-Po Charger (Must be approved for Li-Po Cells!)
<input type="checkbox"/> 3M Satin tape	<input type="checkbox"/> Extra high quality flexible hook up wire.	<input type="checkbox"/> Foam-safe contact glue (sold at most craft stores)
** 11.1 Volts over rates the 350 motor, but is great performance. Use full throttle sparingly.		

Building supplies that make it easy

<input type="checkbox"/> Scissors	<input type="checkbox"/> Sand paper (150, 220, and 320 grit)	<input type="checkbox"/> Steel straight edge
<input type="checkbox"/> Razor saw	<input type="checkbox"/> Hobby Knife and extra blades	<input type="checkbox"/> Small building square
<input type="checkbox"/> Denatured Alcohol	<input type="checkbox"/> Pencil and Pen	<input type="checkbox"/> Wire cutters
<input type="checkbox"/> Soldering iron	<input type="checkbox"/> Assorted screwdrivers	<input type="checkbox"/> Paper towels

Definitions

• LE- Leading Edge	• CA- "Super Glue"	• Brushless- New motors, no brushes, computer controlled.	• 3S1P- 3 cells, 1 Pack • 3S2P- 3 cells, 2 packs	• ESC —Electronic Speed Control
• TE- Trailing Edge	• Brushed- Normal motor type, brushes, can, magnets.	• Li-Poly- New Battery packs. Lithium Polymer (Cell phone battery)	• "C" Rating- the maximum charge or discharge rate of the cell. A 1000 mah pack rated at "10C" could provide a 10 amp discharge. All packs should be charged at "1C"(1000mah pack should charge at 1000 mah max. That means a 1 hour charge time.	

General Construction Notes

- 1) Start by thoroughly reading this manual, and also look carefully at the plans. Many items are addressed more clearly on the plans.
- 2) Normal CA will melt the foam, but odorless CA can be used. Accelerator is a must! It will take hours to dry on its own...
- 3) PAINTING: Painting is not necessary. However, test the paint on a small scrap first. Check the "Painting" section for brands that work well. If masking for painting, use blue low adhesive tape or else when the tape is removed, the film will inadvertently be removed as well. When removing the tape, pull the tape towards any edge of the film so that the film is not pulled loose. You will likely need to put striping tape between the colors as they can bleed under the tape. An alternative to painting is colored packing tape. It is easy to use, self adhesive, and low cost.



Electronics Notes

There are many choices to make when deciding on your power system and it can get confusing. Here is a brief summary of several different motor/gearing/prop combinations that would all be appropriate for this model (all data is from MotoCalc):

Motor	Gearing	Prop	Batt Amps	Watts/lb	Static thrust, oz	Pitch speed, mph	Comments
GWS EPS-350	5.33	8x6	9.7	93.2	14.4	48.7	Max amps and watts with GWS brushed motor for reasonable life
"	"	9x6	12.1	113.0	18.5	43.4	VERY hard on motor
Himaxx 2015-4100	4.43	9x6	11.6	108.7	18.9	43.8	Pitch speed slow
"	"	9x7	12.4	115.8	18.3	49.2	Great combo
"	3.75	9x6	14.2	129.2	20.0	45.0	
"	"	9x7	15.0	135.0	18.9	50.0	
Himaxx 2015-5400	5.33	9x6	12.9	118.7	20.0	45.0	
"	"	9x7	13.8	126.1	19.3	50.5	Great combo
"	4.43	8x6	13.4	122.7	17.1	53.1	
Axi 2212/20	NA	8x6	13.6	124.5	15.6	51.3	
"	"	9x6	15.4	138.3	18.2	43.3	Pitch speed slow
Mega 16-15-5	Direct	6.5x4	15.3	126.1	17.7	56.9	
Razor RZ350	4.43	8x6	9.2	89.1	14.7	49.2	Least current for good performance
"	"	9x7	13.2	122.7	19.7	51.1	Great combo

For good performance, it's important that the motor/gearing/prop used generate 15-20 oz static thrust and a 45-50 mph pitch speed. A program like MotoCalc is invaluable for analyzing different power systems and is highly recommended.

Here are two recommended setups for this model:

Brushed Setup

Motor: GWS EPS-350C with "C" gearing (5.3:1)

Battery: High performance 1000-1500 mAh 3S1P Li-poly pack (capable of supplying at least 10 amps continuous). Note 2 cell Li-poly battery packs cannot be used with this model due to inadequate performance.

Speed Control: Castle Creations Pixie 20

Radio System: 6 channel FM transmitter and a micro receiver. GWS or Hitec servos are recommended (GWS Pico BB, Hitec HS-55, Cirrus CS-5 or 10, Bluebird micros, etc)...**3 are needed**

Charger: Must be approved and designed to charge Li Poly packs. The Kokam charger is great, and so is the Apache 2500

Prop: GWS 8x6 slow flyer

Stuff: Get a few feet of red/black high quality silicone wrapped hook up wire, 2 sets of Deans Ultra plugs

This setup provides excellent performance at minimum expense, generating 15 oz thrust and 50 mph top speed. The downside is the motor won't last long at these power settings (perhaps 3-5 flight hours), but then again the motors are cheap and easy to replace.

Brushless Setup

Motor: Himaxx HA2015-4100 with "B" gearing (4.4:1)

Battery: High performance 1000-1500 mAh 3S1P Li-poly pack (capable of supplying at least 12 amps continuous). Note 2 cell Li-poly battery packs cannot be used with this model due to inadequate performance.

Speed Control: Castle Creations Phoenix 25 brushless controller.

Radio System: Same as above

Prop: APC 9x6 slow flyer or GWS 9x7 slow flyer

The benefit of going brushless is two-fold—better performance and better run time. Plus your motor will last for years instead of weeks. This setup will produce 21 oz static thrust with 50 mph top speed.

Please note this model was designed to be a lightweight parkflyer type of airplane and was not designed to handle extremely powerful motor systems and high flying weights. Thus, avoid the temptation to overpower this model unless you have the knowledge and experience to modify the design appropriately!

About your Plane

Your aircraft was designed by computer (CAD) for accuracy and construction ease. All parts have been precision cut on a CNC laser cutting system right here in the 3D Foamy shop!

The foam used in your kit is the best quality available. The BluCore foam is very light and stiff, and the Depron is very forgiving and easy to paint. However, because we want weight at the minimums, the planes are still somewhat fragile, so a little care can go a long way.

Note that this model is intended for experienced modelers, and is not suitable for beginners. If you're comfortable flying a fast sport aerobatic airplane, you can probably handle this model.

I hope that you are going to enjoy building and flying this plane as much as I have! Best of luck, and don't hesitate to e-mail me with any questions or comments at levi@3DFoamy.com.

P.S. If you think I can improve or clarify something in this manual, please let me know!

-Levi Jordan

Construction

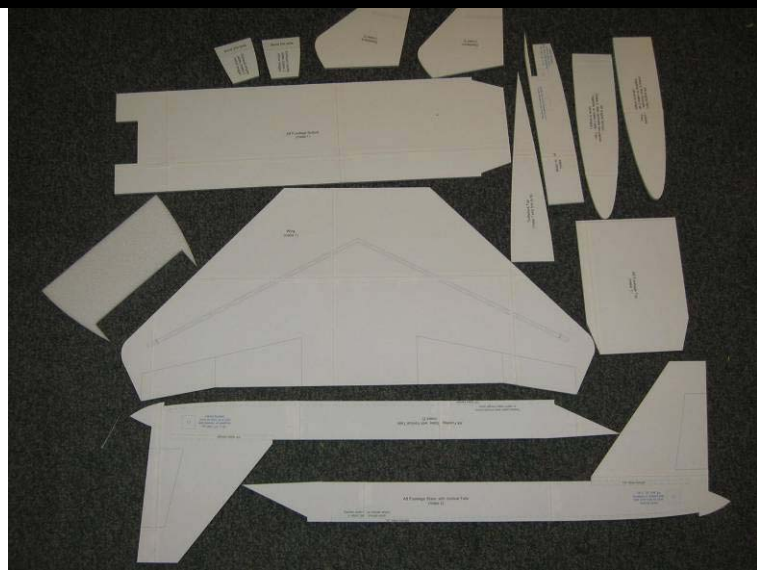

All parts have been accurately cut on a computer controlled laser cutting machine. Remove the aircraft parts from the foam packing sheets. Cut the tabs loose with a razor blade for best results.

Get friendly with your glue of choice. Different situations call for different adhesives, and this model is best built using the following types:

- Epoxy (both 5 minute and 30 minute)
- Foam-Safe CA (with accelerator)
- Contact glue such as GWS contact cement, UHU Por, UHU Creativ for Foam, or craft store foam contact glues
- 3M 77 spray adhesive

ProBond can also be used in place of epoxy. It is lighter than epoxy and just as strong, but takes much longer to cure.

If you're building this model from BlueCore foam instead of Depron, you'll need to peel the film backing off of all fuselage parts to allow sanding the fuselage corners round. Leave the film on the wing and tail parts since it adds strength and smoothness.

Note that all of the construction photos shown here are of the prototype F-15 Park Jet, which differs slightly from the production version. However, the general procedure and construction principles are the same.

1. Begin by assembling the forward fuselage. Lay the two fuselage sides down flat on the work bench and glue the triangle stock to the locations shown. Make sure to make two mirror image parts—a left side and a right side. Either contact glue or odorless CA works best for this step since they cure so quickly. UHU Creativ for Foam was used exclusively on the prototype model.

After the glue has dried, glue the three fuselage bulkheads to one of the fuselage sides at the locations shown, making sure they are perpendicular.

2. Next glue the two fuselage sides together. Set the sides upright and flat on the workbench, apply glue to the edge of the bulkheads (contact glue or odorless CA recommended), and push the sides together. Note the aft end is left open at this point—it will be glued together later after the aft fuselage assembly is attached.

After the glue has dried, glue the forward fuselage bottom piece to the bottom.

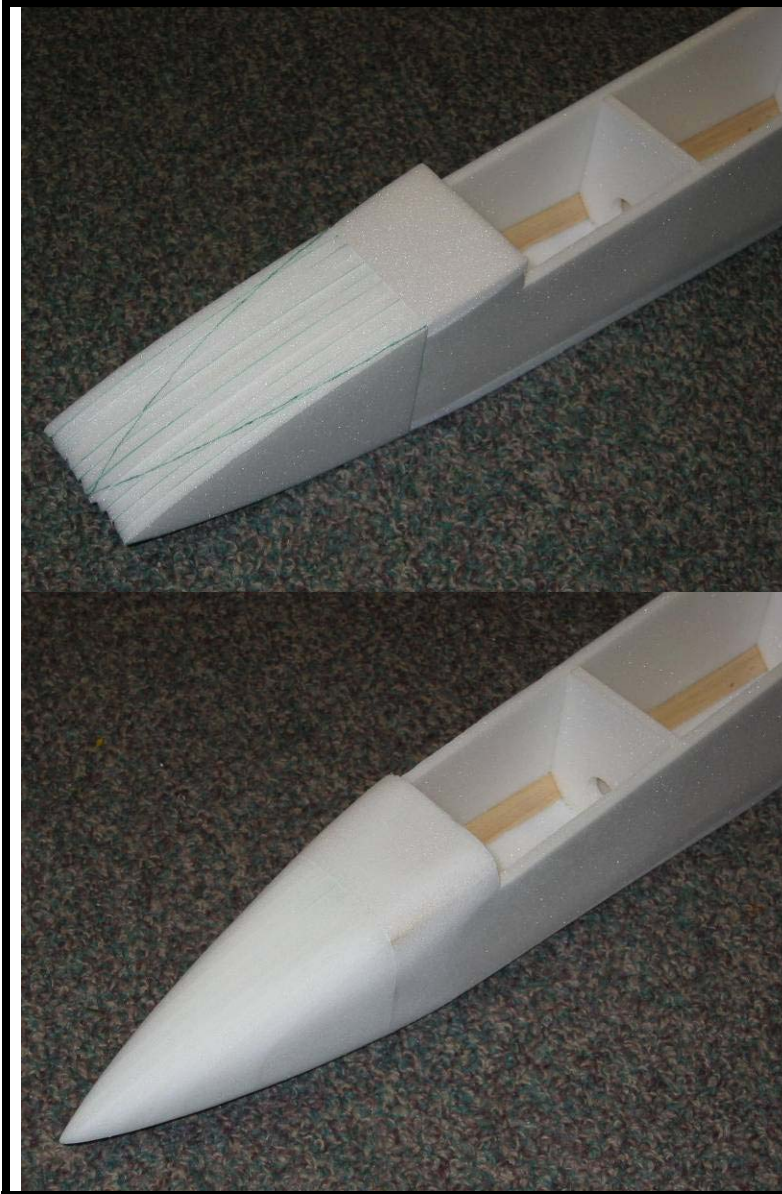

3. Glue on the foam nosecone block and the forward fuselage top piece as shown (5 minute epoxy recommended).

Once the glue has dried, sand the nosecone and forward fuselage to shape. Start with coarse sandpaper (100 grit) to rough out the basic shape, then move to a finer sandpaper (220 grit) to do the final shaping. End with 320 grit sandpaper to do the final polish sanding and provide a very smooth surface.



4. Carve the canopy to shape using the same procedure as the nosecone.



5. Now begin assembly of the aft fuselage. Notice on the plans how the fuselage top and bottom have a gentle curve at the aft end of the fuselage that forms the exhaust nozzles. Assembly of these parts goes much easier if you first pre-form these curves into the foam pieces using a heat gun. This is very easy to do! Just hold the heat gun about a foot or two away from the foam and heat the foam SLIGHTLY (it doesn't take much). Then gently bend the foam with your hands to the curves required (note the foam will spring back some, so the initial bends need to be slightly more than what's required). If you bend the foam too much don't worry about it—it's easy to reheat the foam and take the bend back out. To judge how much curvature is required for each piece, simply hold it up next to the part it attaches to and keep bending it until it matches fairly closely.



6. Glue the triangle stock, foam support strip, and plywood stab mounts to the two fuselage sides (make sure to make left and right mirror images).

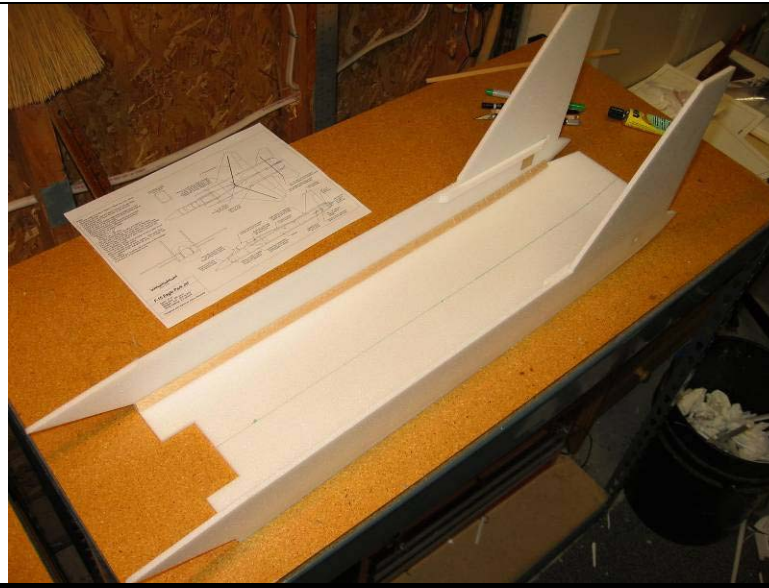

7. Draw a centerline on the inside of the fuselage bottom piece. This line will help with aligning other parts later.

Glue the two fuselage sides to the bottom piece (the centerline should be on the inside as shown).

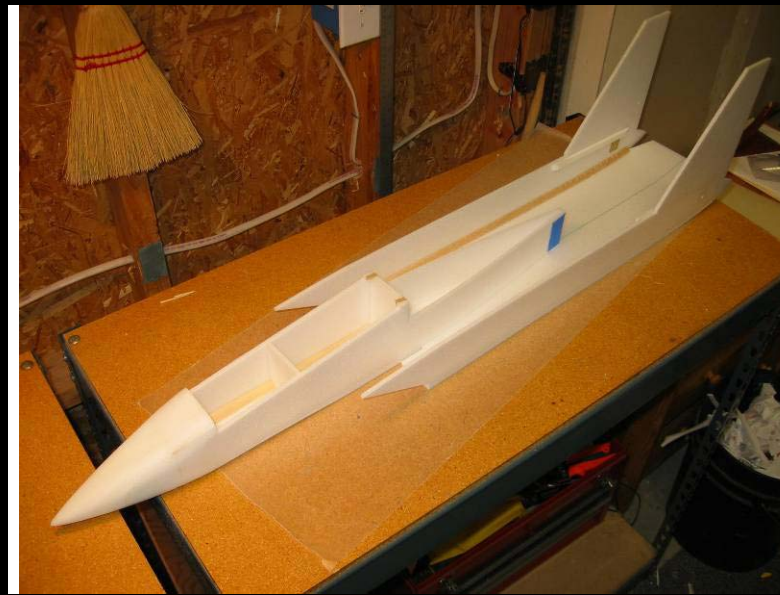

8. Now glue the forward and aft fuselage assemblies together. Draw a small centerline mark on the inside of the forward fuselage bottom piece, and align that mark with the centerline of the aft fuselage piece. Apply glue (5 minute epoxy recommended) to the bottom edges of the forward fuselage sides, and to the free aft ends of the forward fuselage sides. Then temporarily tape the two free aft ends of the forward fuselage together. Make sure everything is properly aligned, then press the forward fuselage down onto the aft fuselage on a flat surface. Adjust the taped ends of the forward fuselage as required to make sure they are aligned on the centerline of the aft fuselage. Let this cure thoroughly.



9. Laminate the two identical motor mount supports together (3M 77 spray adhesive recommended). After the glue is dry, glue in the hardwood motor mount with 5 minute epoxy and let it cure. Check the fit of the elevator servo used, and trim or shim the foam as required for a tight fit. Glue the plywood stabilator support pieces to each side of the motor mount supports, centered over the stabilator pivot holes.

Glue the motor mount support into the aft fuselage (5 min epoxy recommended), making sure it is aligned with the centerline drawn on the fuselage bottom.

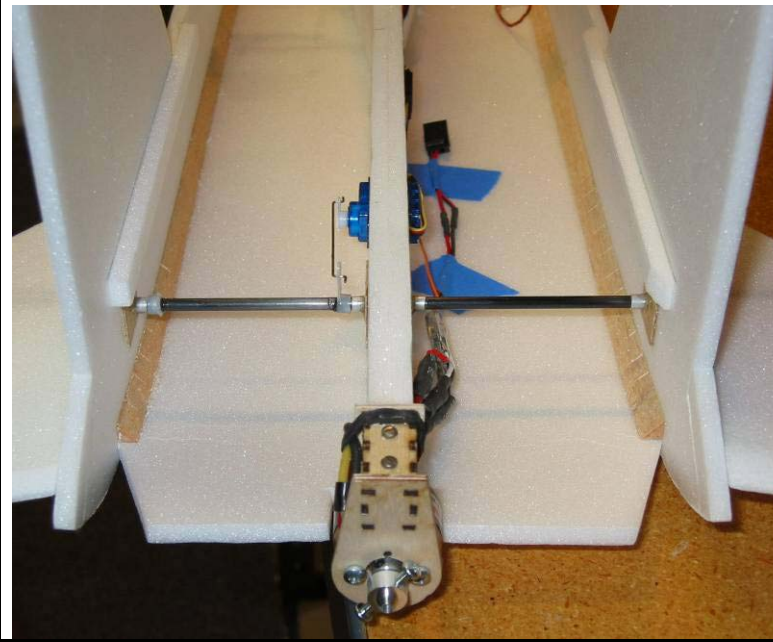
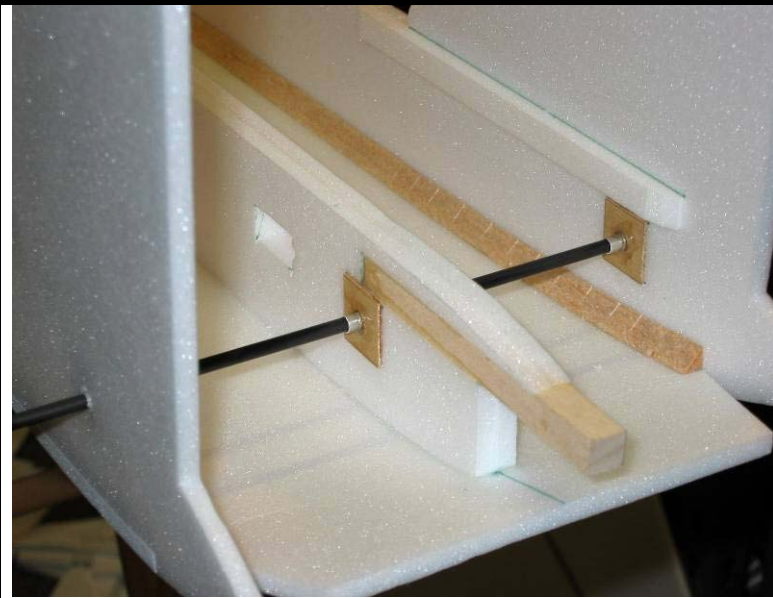

10. Next install the hardware for the pivoting stabilators. The .157" diameter carbon stabilator rod pivots inside three short pieces of 3/16" diameter aluminum, which are supported by four small squares of 1/64" ply glued to the fuselage sides (study the plans carefully here!).

Drill 3/16" holes through all of the plywood stab pivot supports. Use the precut holes in the foam to guide the drill for the outer pieces, then push the drill bit through and hold the drill as square as possible while drilling the center plywood pieces. Then test fit the three aluminum tube bearings into the holes and try to slide the carbon stabilator rod in to check fit. If your drilling was a little off (and it probably was), you may need to enlarge the hole in the center motor mount slightly to reposition the bearing and allow the carbon rod to turn freely (don't worry about creating gaps here, since we'll use epoxy to glue this tube in which will fill the gaps).

Once everything fits and the carbon rod turns freely, apply 5 minute epoxy around each of the three aluminum tubes to glue them in place. Note the carbon rod should still be inside the bearings to hold them in alignment—but make sure not to get epoxy on the carbon rod.

Once the epoxy is cured, remove the carbon rod. Two parts then need to be slid onto the carbon rod—the control horn and the end stop bearing. Both of these parts are on the left side of the fuselage between the fuselage side and motor mount (the control horn goes in the center and the end stop goes on the outboard end), and are what keeps the carbon rod from sliding left and right so the stabilator edges don't rub against the fuselage sides. Slide the carbon rod back in to the fuselage, sliding these two parts on at the same time (but don't glue them in yet).



11. Shape the stabilator leading and trailing edges with fine sandpaper (220 grit), sanding a round contour on the leading edge and a tapered contour on the trailing edge. Then glue the left stabilator onto the carbon rod with 5 minute epoxy, making sure the carbon tube is centered in the fuselage.

After the glue cures, glue on the right stabilator, making sure it is aligned with the left stabilator and that both stabilators are flush with the fuselage sides. Once the glue is cured, check the stabilator pivoting and make sure it turns freely. Touch up sand the fuselage sides and/or stabilator ends as required so that they don't rub.

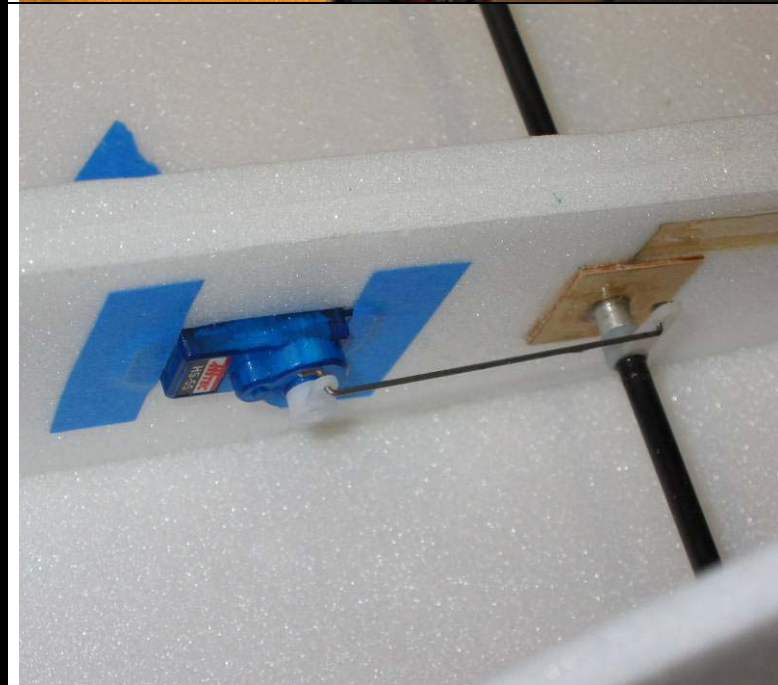

12. Now install the elevator servo. The servo should fit very tightly, and short pieces of tape are used to hold it in place.

Make a pushrod from 1/32" music wire and install it (Z-bends are recommended at both ends).

After the pushrod is installed, get everything aligned:

- Center the servo arm vertically
- Center the stabilator control horn vertically
- Make sure the stabilators are flush with the fuselage sides and at neutral (0 degrees deflection)
- Make sure the end stop and control horn are flush against the aluminum tube bearings (so that there's no side-to-side motion)

After all of these are aligned, glue the control horn and end stop to the carbon rod with CA glue and accelerator.

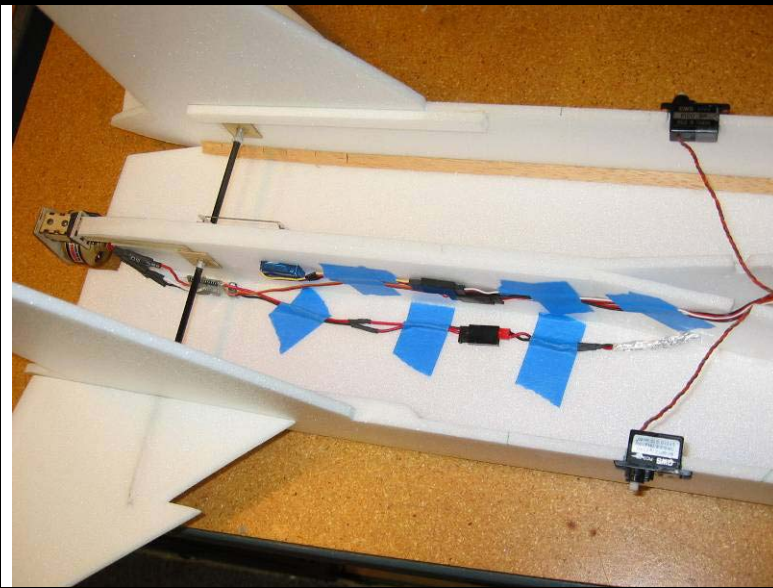

13. Next install the receiver and speed control. The receiver fits in the aft part of the center fuselage, and the ESC is installed wherever is most convenient inside the inlet ducts. A small hole must be cut in the foam wall of the receiver compartment to pass the speed control and elevator servo leads. Tape all wires leading to and from the speed control and servo to the fuselage sides inside the inlets. Plug the elevator servo leads into the receiver.

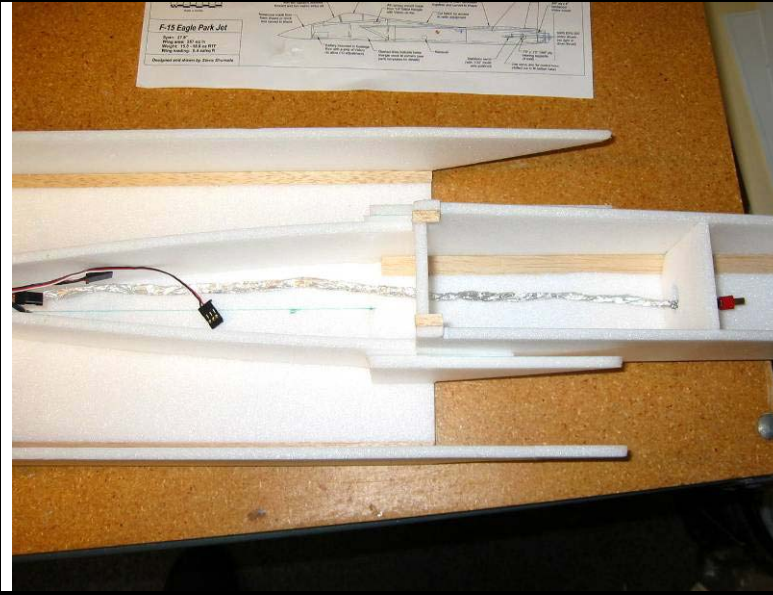

14. Make a wire extension to connect the battery in the forward fuselage to the ESC in the aft fuselage. Use at least 16 gauge wire. To reduce the amount of RF interference with the receiver, twist the wires in the extension together and also wrap them tightly with 3 or 4 layers of household aluminum foil. This will provide shielding that should reduce glitches. Solder the connectors of choice to both ends (Deans Ultra connectors are recommended).

For most installations, the battery will probably end up at the very forward end of the battery compartment, so make sure to make the wire extension is long enough to reach that area.

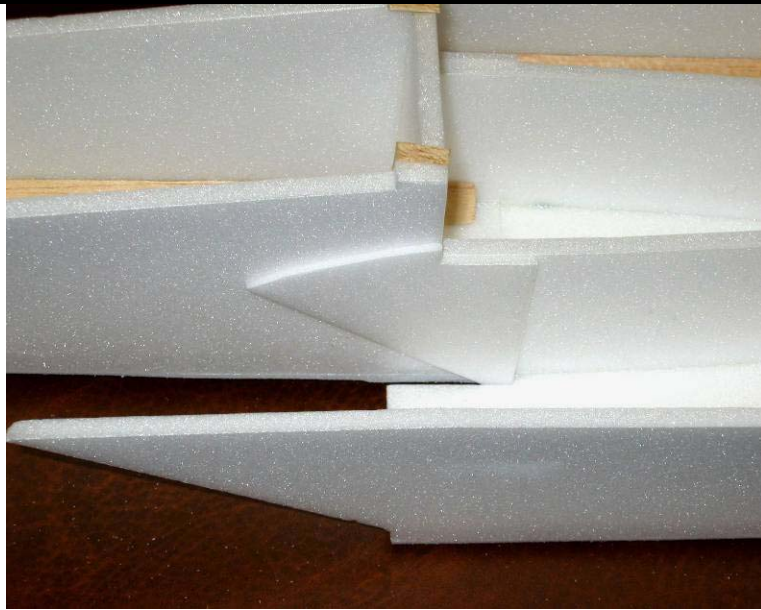

15. To provide a scale-appearing inlet boundary layer diverter, there are two pieces that are installed in the inboard side of the inlet openings. The inner piece is made of 3mm Depron and provides the scale gap between the inlet and fuselage. The other piece is 6mm Depron and forms the inboard side of the inlet itself.

Glue the inner pieces to the fuselage sides first as shown in the top picture at left, then glue the second piece on top of the first as shown in the bottom picture.



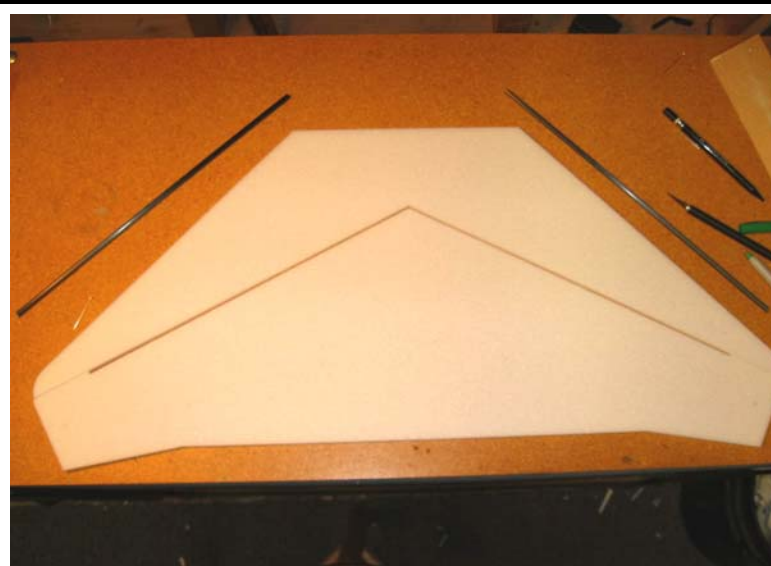

16. Begin wing construction. Start by sanding the wing leading edge to a round shape and the wing trailing edge to a tapered shape.

Cut a V-shaped notch in the foam to fit the carbon tube wing spar.

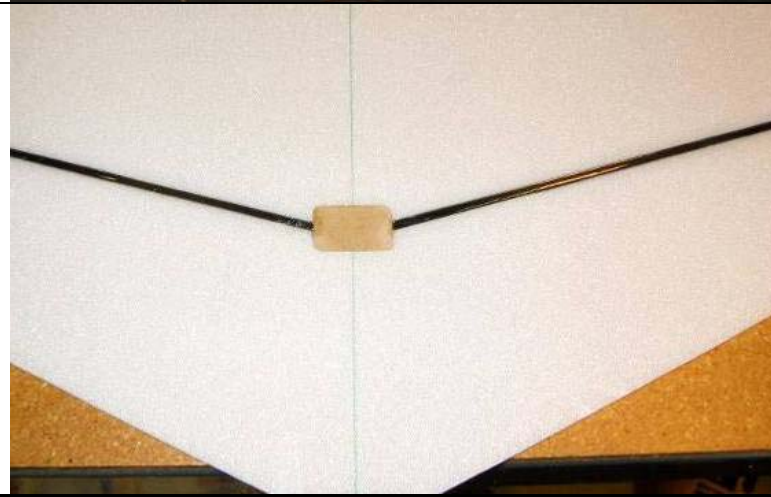

17. Lay the wing down on a flat surface and use 30 minute epoxy to glue the carbon spars in place. Place heavy books over wax paper on top of the wing to hold the wing perfectly flat as the glue cures. After the glue cures (give it a least 2 hours), install the two small 1/32" plywood doublers on the top and bottom of the spar joint at the center section using 5 minute epoxy.

Next cut the flaperons free from the wing. Then cut a 45 degree bevel in the leading edge of the flaperon using a ruler and a hobby knife.

Hinge the flaperon to the wing using your hinge of choice. I used 3M Satin tape on top and bottom, running full span.



18. Test fit the wing strake piece and the wing together on the fuselage. Make sure both line up on the fuselage centerline, and that the strake edges line up with the inlet sides. Trim and adjust if required, and once satisfied with the fit glue both pieces in place using epoxy.

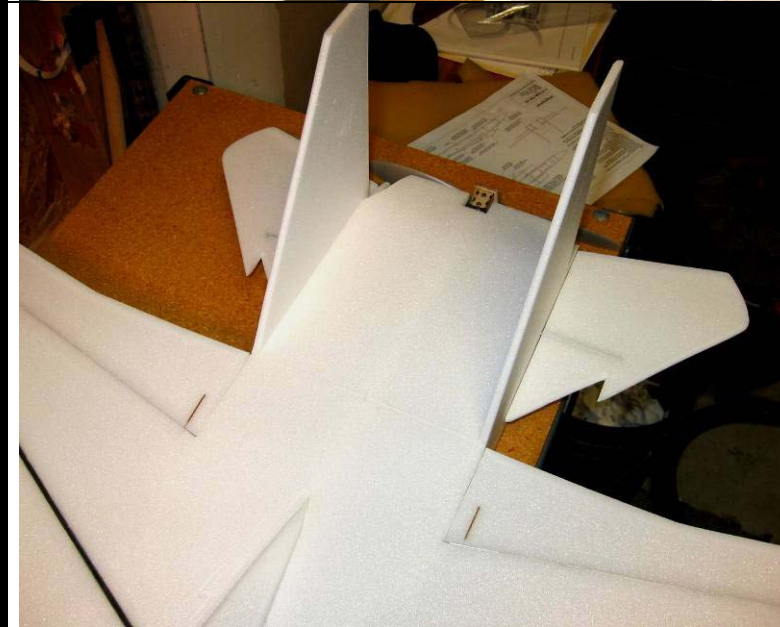

19. Next install the top of the aft fuselage. This piece should be pre-formed with a heat gun to the proper curvature before installation. Note this piece attaches to the tops of the foam support strips that were glued to the fuselage sides earlier.

After the glue is cured, sand the leading and trailing edges of the vertical tails round.

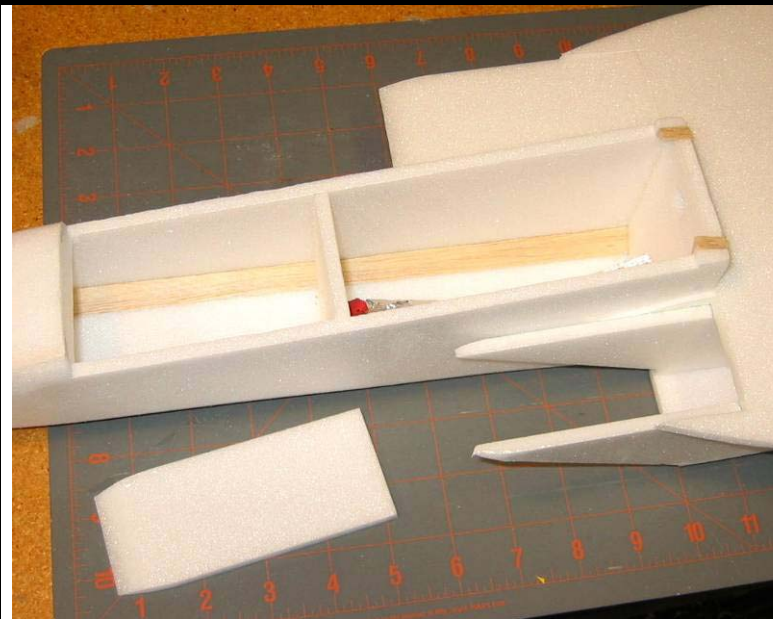

20. Install the forward inlet tops. First cut a long bevel in the bottom leading edge of each piece as shown on the plans. Then glue the pieces in to the tops of the inlet sides and the sides of the wing strake piece.

A view of the completed inlets is shown in the bottom picture.



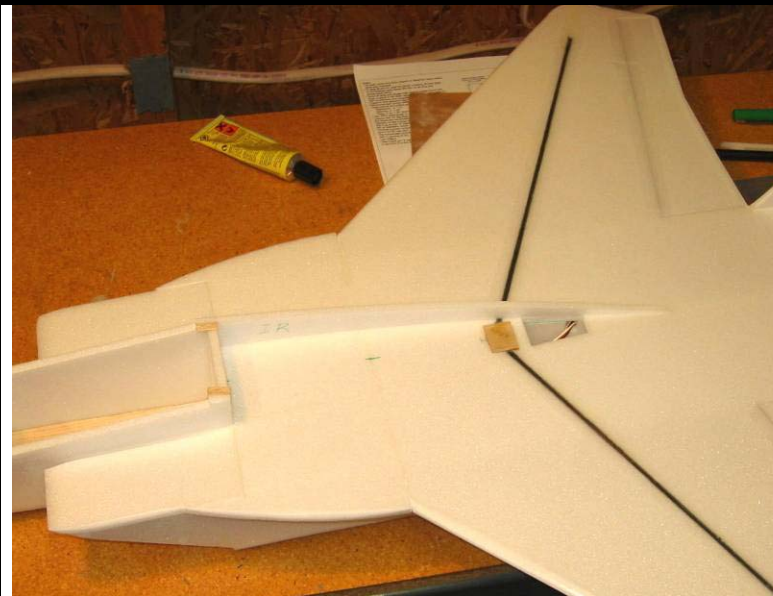

21. Install the fuselage turtledeck. First glue the turtledeck sides to the top of the wing, taking care to approximate the curvature shown on the plans and to join the ends on the fuselage centerline (drawing a centerline first will help).

After the glue is dry on both sides, glue the turtle deck top piece on.

After that glue dries, sand the corners of the turtledeck round.

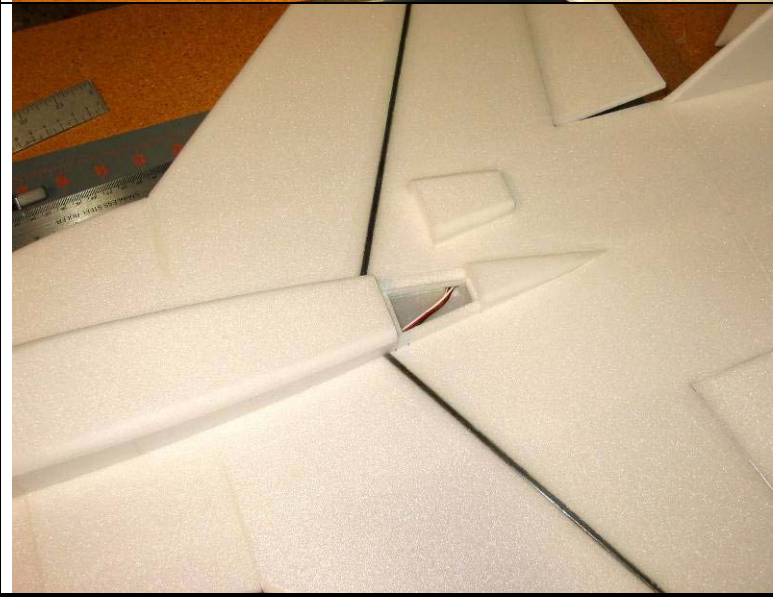

22. Cut an access hatch in the turtledeck above the receiver compartment to allow access to the receiver and servo leads. I use small strips of Satin tape to keep this hatch on in flight.

I also recommend applying a single strip of 3M Satin tape around the wing and tail leading edges at this time. The tape helps provide a very smooth leading edge shape and also provides more durability against the inevitable "hangar rash."

If you haven't yet done so, sand all fuselage corners round.

23. OPTIONAL STEP: Parts are provided to make scale-looking engine fairings on the top of the aft fuselage. These parts improve the scale appearance of the model, however, they add 0.3 oz of weight to the aft end of the model—which is often already tail heavy (meaning more ballast has to be installed in the forward fuselage for balance). Thus, the installation of these pieces is at the discretion of the builder. If you're using a high-powered brushless motor and large batteries and aren't so worried about weight and balance, it's fine to install these pieces. But if you're building a lightweight parkflyer and using a smaller motor and battery, you should probably leave these off.

To install these fairings, start by sanding the foam pieces to a rounded top with feathered edges on the sides (see top picture). Then glue in place as shown in the middle picture (note these pieces will need to be gently curved with a heat gun to match the curvature of the fuselage top piece). The bottom picture shows what the model looks like with these pieces installed.

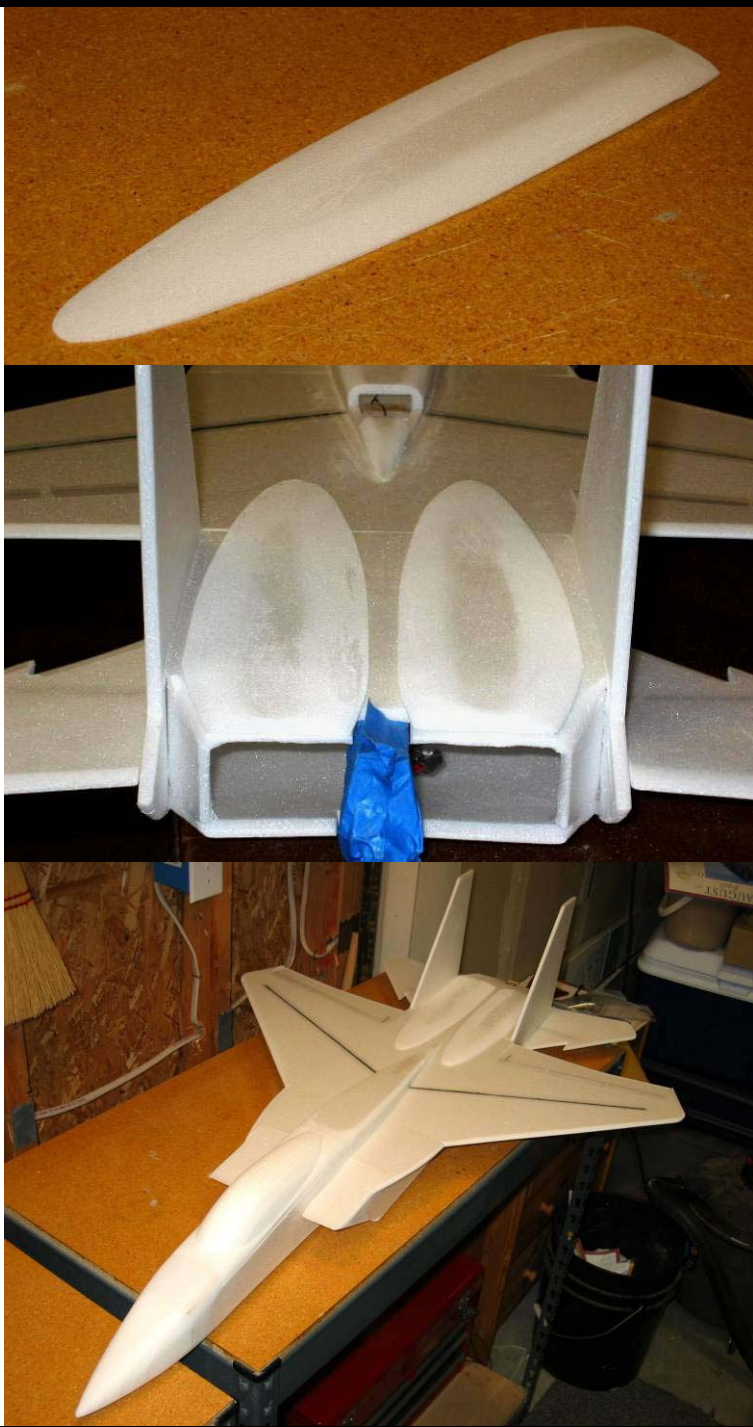

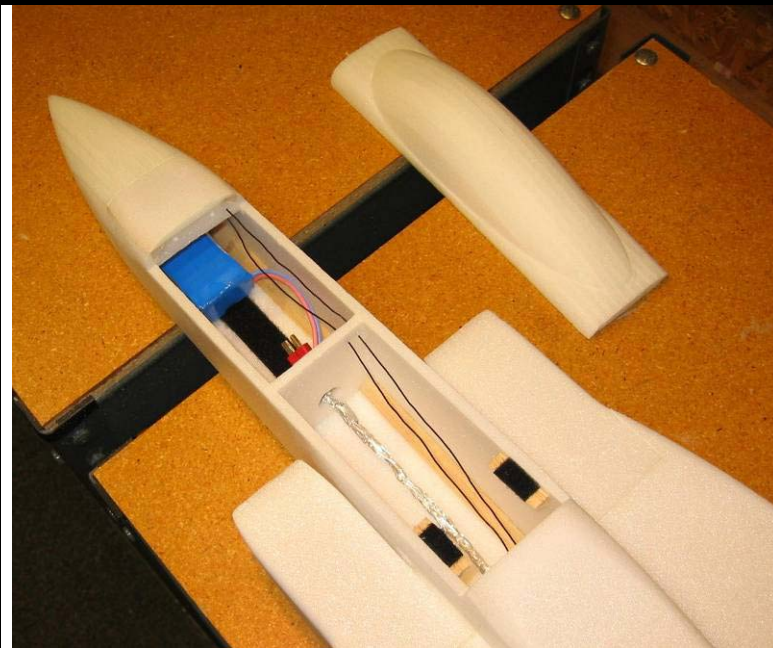

24. The canopy is removable to allow easy access to the battery compartment. It is held in place with two bamboo skewers forward (toothpicks or carbon rod could also be used) that slide into matching holes in the forward bulkhead, and two small strips of Velcro aft that are mounted to short pieces of $\frac{1}{4}$ " balsa triangle stock.

Cut two 2" lengths of bamboo and sharpen both ends. Stick the bamboo into the foam at the front of the canopy so that only $\frac{1}{2}$ " protrudes and glue into place.

After the glue dries, push the canopy onto the airplane so that the protruding ends poke holes into the forward bulkhead. Then glue the Velcro mounts to the fuselage sides as shown on the plans and attach the matching Velcro pieces to the mounts and to the canopy.



25. Initial construction is now complete. If painting the model, see the "Painting Information" section for more info.

After painting, proceed to the next step.

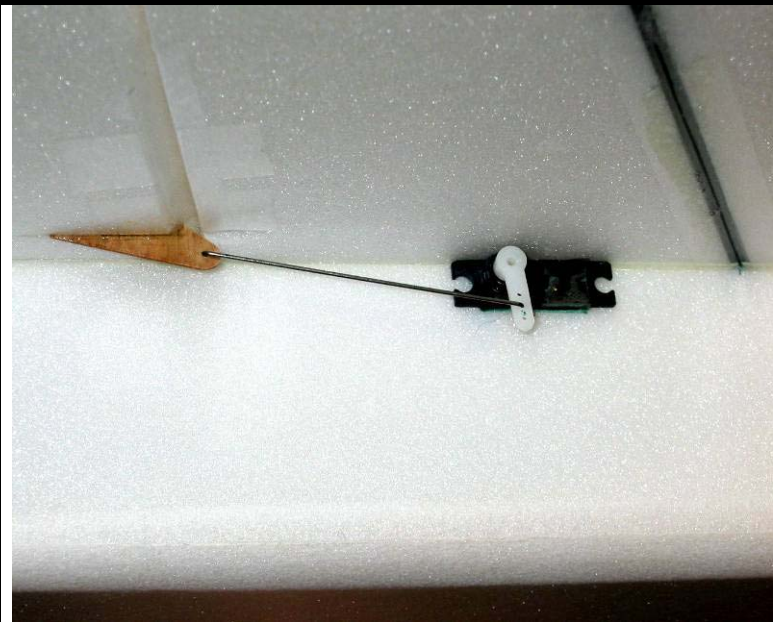

26. Install the flaperon servos into the precut holes in the fuselage, and plug the servo leads into the receiver. The servo is held in place simply by friction (thus it's important to have a tight fit). If the servo gets too loose, just wrap it with a strip or two of tape to restore the tight fit.

Install the flaperon control horns, and make a pushrod from 1/32" music wire (using Z-bends at both ends).

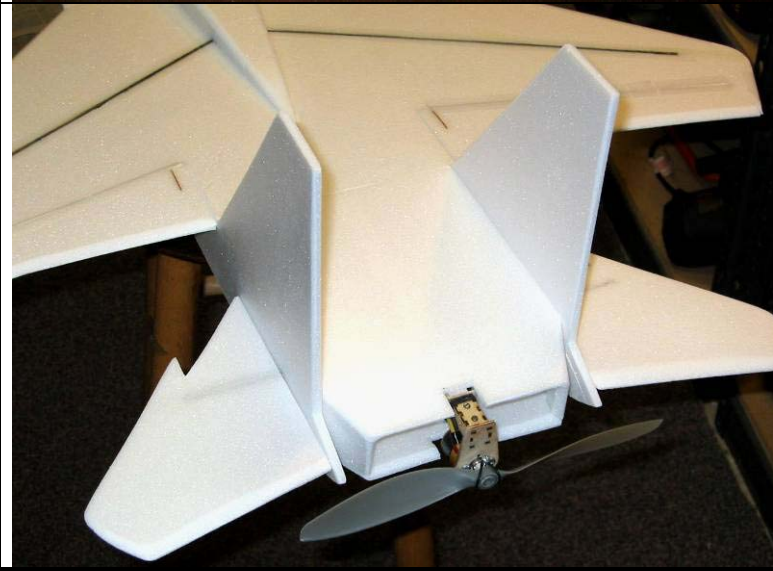

27. Attach the motor to the motor mount. Two screws on top hold the motor onto the wood mounting stick.

Plug the motor into the leads to the speed control.

Note that a "soft-mount" prop adapter is highly recommended on this model to prevent damage during landings.



28. Test install the battery inside the forward fuselage to see where it needs to be to provide the correct center of gravity. The prototype model required the battery almost all the way forward. With heavier motor installations, ballast and/or a larger battery pack may be required to balance this model.

After the battery location has been determined, apply a strip of Velcro to the centerline of the fuselage and to the battery. This keeps the battery in place and also allows easily adjusting the center of gravity later.

CONGRATULATIONS! Your model is now complete!

Additional Photos



Painting Information

1. Createx, Rustolium, latex, Testors, Tempra, markers, sign vinyl, and many more, are just some of the choices you can make for the final paint. Just test on foam squares before using it on the whole plane! **I recommend using Testers Model Master Spray Enamel, or Krylon "Short Cuts" spray enamel (small \$2.00 can). Neither of these paints will attack the foam.** The prototype F-18 Park Jet was painted in Blue Angels colors using standard acrylic craft paint (available for \$.99/bottle from most craft stores) applied with an airbrush (two light coats were required). The yellow trim is Coverite trim sheets, and the Blue Angels decals were printed using a standard inkjet printer and paper label material.
2. Be wary of weight. Use light coats to keep weight to a minimum. For reference, a full coat of lightly sprayed acrylic paint on this model adds 1.0 oz.
3. To keep weight to a minimum, use the foam's natural color in your paint scheme if possible. Mask off the areas you don't want painted then shoot it with a fine mist. Let it sit for 5 minutes then mist a second coat. It should almost be covered now. Repeat the process for each paint color.
4. As an option, you can apply strips of clear packing tape to the bottom of the fuselage to protect it from abrasion during landings.

Flight Setup

1. This model flies at it's best with flaperon controls enabled, which requires a transmitter with flaperon mixing. If you don't have one, this model can still be flown satisfactorily with ailerons only. Just use a Y-harness to plug the two aileron servos into the receiver. The use of flaps will not only improve takeoff and landing performance, but also improve maneuverability.
2. Adjust the controls to provide the following recommended deflections (all dimensions are measured at the root trailing edge):
 - Stabilators: +/- 2.0"
 - Ailerons: +/- 1.5"
 - Flaps: 0 up, 1.5" down
3. I recommend using -40% exponential rates on elevator and ailerons.
4. Recommended hand launch procedure: Grip the airplane near the CG, set 10 degrees flaps (optional) and 50% throttle, and throw it moderately hard straight ahead and parallel to the ground. **Be careful to keep your hand away from the prop as you throw it!** Slowly add throttle soon after launch, and after the model has gained some speed and altitude retract the flaps if desired. When flying in small fields, the flaps should be set at 10 degrees throughout the flight, which will allow the model to fly slower and turn tighter. If you're flying in a larger field and want faster speeds or better aerobatics, retract the flaps to zero after launch.

5. While landings can be made with no flaps, adding up to 30 degrees flaps before landing really helps slow the airplane down and allows it to float in much easier. You'll find that this model is capable of beautiful slow nose-high landings.

6. **WARNING: Remember to ALWAYS release the elevator control right before touchdown during landings, since the forward stabilator tips can dig into to grass or soft ground—which can significantly damage the model and/or stabilator servo! Also remember to pull the throttle back to zero just before touchdown so that the propeller and/or motor mount is not damaged on landing.**

Programming The Speed Controller

If you have a problem with the speed control malfunctioning during set up it may be because of radio interference from the servos. Disconnect the servos, and then start the programming sequence again.

PIXIE 20 BRUSHED SPEED CONTROLLER recommended set up:

- 9.1: Option 3 for 2-cell LiPoly packs; Option 5 for 3 cell LiPoly packs
- 9.2: Option 2 – soft cutoff
- 9.3: Option 1 – Auto calibration

PHOENIX 25 BRUSHLESS SPEED CONTROLLER recommended set up:

- 9.1 Option 5 – 8.4v cut off for 3 cell LiPoly (in conjunction with (f) below)
- 9.2 Option 3 – Standard current limiting
- 9.3 Option 5 – Brake Disabled
- 9.4 Option 1 – Auto Calibrating throttle
- 9.5 Option 2 – Standard Advance Timing (may cause prop to jump at start up)
- 9.6 Option 3 – Soft cutoff
- 9.7 Option 3 – Fast Start (for fast throttle response – essential for hovering)

Battery Charging

There are many battery chargers available. If you use a Duralite Lilon charger the Rx charge jacks are for 2-cell packs and the Tx jack is for 3-cell packs. **You must use a Li-Ion or Li-Poly charger on Li-Ion/Li-Poly cells or you will damage the cell or the cell could explode.** All Li-Poly cells should only be charged at a 1C. This means if you have a 1500 mah pack, it should only be charged at a maximum rate of 1500mah or 1.5 amps. Exceeding this will shorten the life of your cells, and can even cause a serious fire!!! (Yes, cars have gone up in flames from over charging!)

Flight Check List

- ✓ Check the CG. Set it as recommended.
- ✓ Check all control surface directions!
- ✓ Check all battery polarity connections.
- ✓ Check for any control binding, free as needed.
- ✓ Check your radio range. It should be at least 100' with the antenna down.
- ✓ Setup your speed control to match your battery pack.

Repairs

Should the inevitable happen, here are some tips:

- Cracks in the foam are fixed with some foam safe CA. Just use accelerator to speed up the process.
- Almost anything is repairable. I cracked my plane in 5 pieces, and everyone thought it was finished. 15 minutes later it was flying. Just take some CA, accelerator and packing tape to the field with you!

If you are using more then 2 bottles of CA a day for fixes... order some more kits! 😊

If worse comes to worse and you crack up your plane beyond repair, then go to www.3dfoamy.com and order a new one! I'll even give you 20% off as a returning customer, just enter "20off" in the redeem coupon code box to get the discount.

Best of flying to you, and I hope you have enjoyed building this kit as much as I have designing them!
Remember to send your pictures and videos to post on the website!!!

“I live for this stuff!”

3D Foamy (Levi Jordan)

12811 West Fourth Ave

Cheney, WA 99004

[Help@3DFoamy.com.com](mailto:Help@3DFoamy.com)

www.3DFoamy.com